

# HIGH RISE™

## Portable Restroom Assembly Instructions

**INTRODUCTION:** *Satellite portable restrooms and accessories must be assembled according to approved assembly procedures. Variations in assembly could adversely affect product life and warranty.*

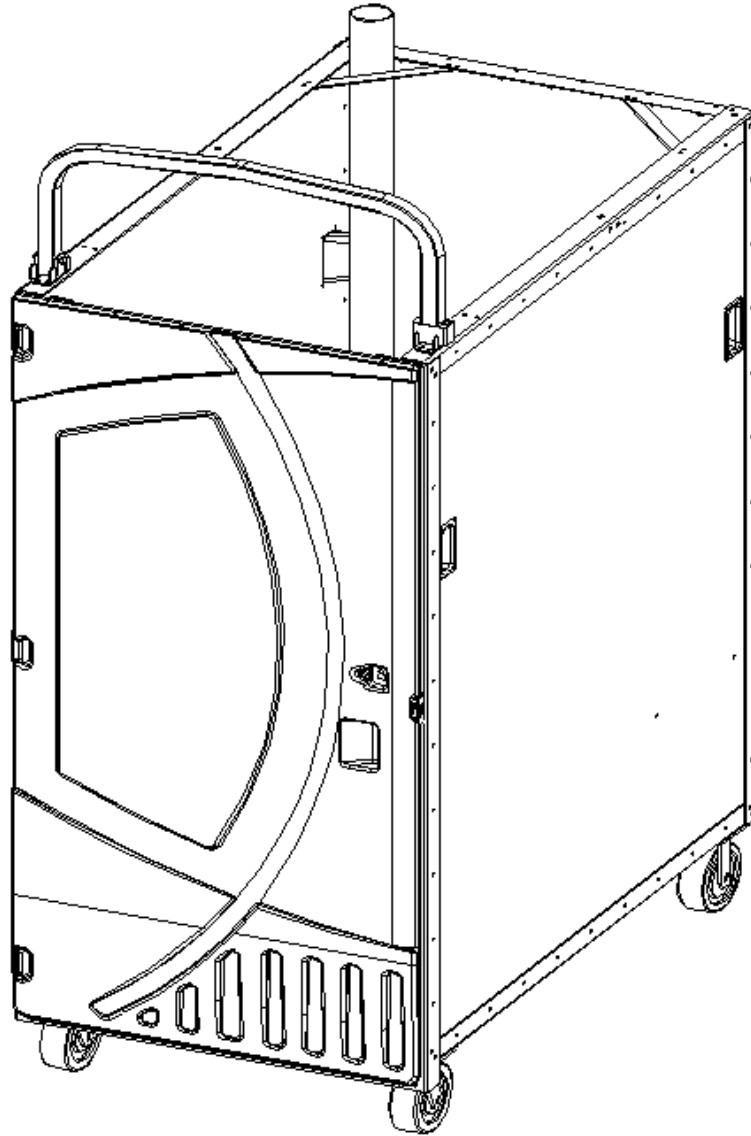

2530 Xenium Lane North, Minneapolis, MN 55441  
Telephone: 763-553-1900 Fax: 763-553-1905  
800-328-3332 / [www.satelliteindustries.com](http://www.satelliteindustries.com)

Note: The assembly procedures are written for assembly of single units. If assembling multiple units, considerable efficiency can be gained by having a crew working in assembly line fashion.

## TOOLS:

- DRILL ELEC/CORDLESS    - SOCKET DRIVER BIT    - RIVET GUN    - ADJUSTABLE WRENCH    - 1/4 DRILL BIT
- #10 (.193) DRILL BIT    - 3/8" HEX NUT DRIVER BIT    - 7/16" OPEN END WRENCH    - 7/16" SOCKET
- 1/2" OPEN END WRENCH    - 1/2" SOCKET    - 9/16" OPEN END WRENCH    - 9/16" SOCKET

## HELPFUL HINTS

- Have an apron with at least two large pockets, easy to get parts out of
- Don't open up all your kit boxes. Open up only enough kit boxes to assemble the number of toilets you are currently working on. **KEEP PARTS ORGANIZED.**

## EXPLODED UNIT ASSEMBLY DRAWING

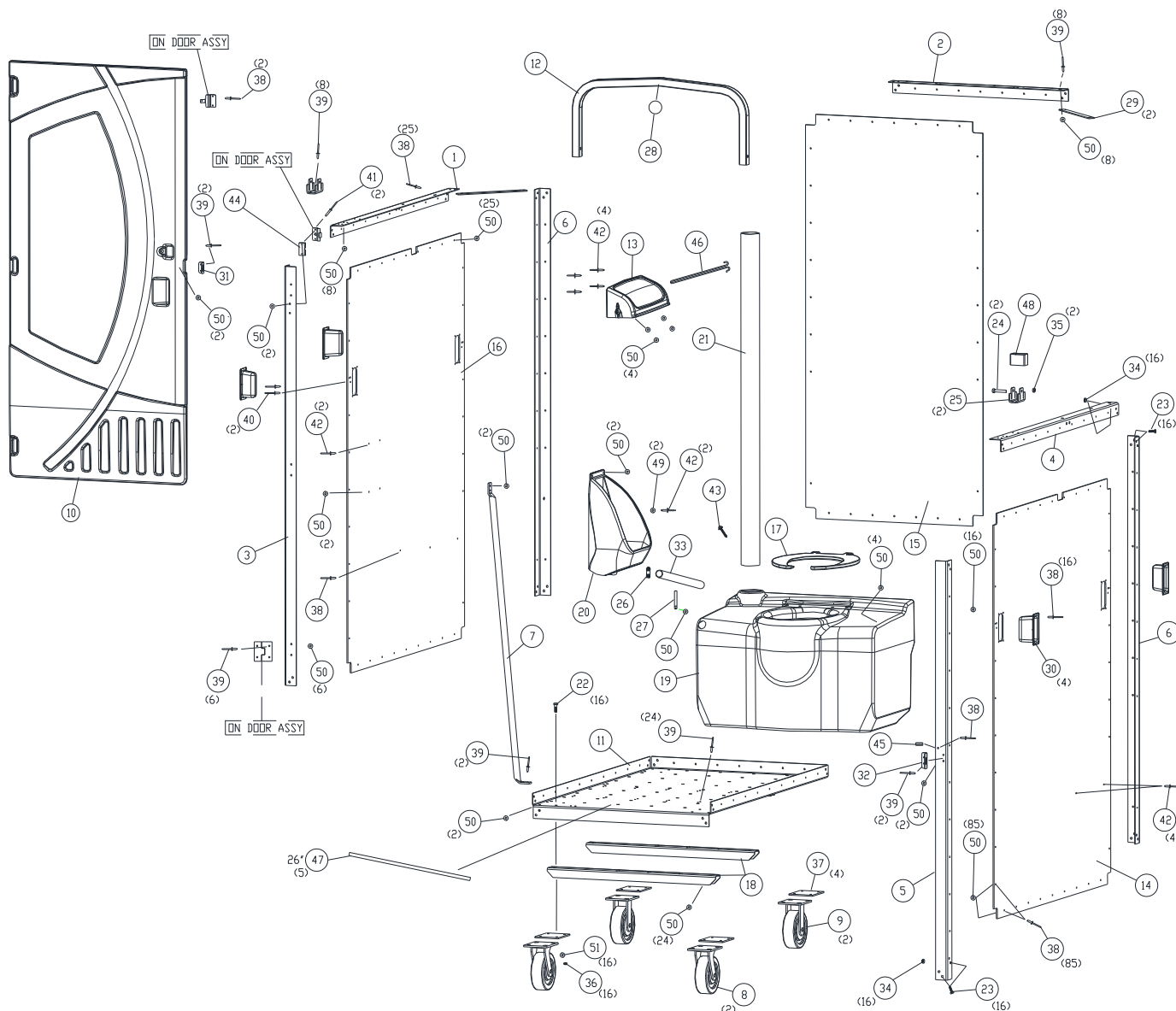



# HARDWARE: HDWE, HIGH RISE 20848

- 22  PN 21919

23  PN 17385

24  PN 17915

25  PN 20807

26  PN 12588

27  PN 20817

28  PN 20916

29  PN 20809

30  PN 20810

31  PN 13197

32  PN 13199

33  PN 13417

34  PN 16307

35  PN 20805

36  PN 13131

37  PN 20811

38  PN 11027

39  PN 11270

40  PN 14351

41  PN 10812

42  PN 11054

43  PN 13860

44  PN 20804

45  PN 20620

46  PN 22310

47  PN 20919

48  PN 20815

49  PN 10068

50  PN 11315

51  PN 11364

## HDWE, HIGH RISE ( 20848 )

51	11364	16	WASHER, 1/4 FLAT
50	11315	195	WASHER, 3/16 RIVET STNLS
49	10068	2	WASHER, RUBBER 3/32 THK
48	20815	1	TUBE, HIGH RISE PROP LOCK
47	20919	130"	STRIP, 1in ANTISLIP
46	22310	1	SPINDLE- PRGRD II 3 ROLL METAL
45	20620	1	SPACER, TM II URINAL ALUM
44	20804	1	SPACER, CABLE ANCHOR BRACKET
43	13860	1	SCREW, #14 X 1-1/2 W/WSH GOLD
42	11054	12	RIVET, #68 AAL POP
41	10812	2	RIVET, #612 ALUM
40	14351	4	RIVET, #610 CCP
39	11270	50	RIVET, #68 STNLS
38	11027	130	RIVET, #66 ALUM
37	20811	4	PLATE, CASTER MOUNT HIGH RISE
36	13131	16	NUT, 5/16 NYLOC
35	20805	2	NUT, 3/8-16 NYLOC THIN
34	16307	32	NUT, 1/4-20 NYLOC STNLS
33	13417	21"	HOSE, 1in ID BULK COIL
32	13199	1	HASP, 3/16 RIVET HOLE FACING
31	13197	1	HASP, 3/16 RIVET HOLE DOOR
30	20810	4	HANDLE, POCKET HIGH RISE
29	20809	2	GUSSET, HIGH RISE CORNER
28	20916	1	DECAL, HIGH RISE DO NOT LIFT
27	20817	1	CLAMP, INSULATED HIGH RISE
26	12588	1	CLAMP, WORMDRIVE #12
25	20807	2	BRACKET, PROP FRAME HIGH RISE
24	17915	2	BOLT, 3/8-16 X 2 GRD8 PLTD
23	17385	32	BOLT, 1/4-20 X 3/4 GRD5 PLTD
22	21919	16	BOLT, 5/16-18 X 1 GR5 PLTD
ITEM	PART#	QTY	DESCRIPTION

## STANDARD HIGH RISE PARTS

21	20816	1	VENT PIPE, 3 X 52-1/2 BLACK
20	11999	1	URINAL, SPLASHGUARD GREY
19	20814	1	TANK, 38 GALLON HIGH RISE
18	20852	2	SUPPORT, HIGH RISE FLOOR
17	14959	1	SEAT, ELONG MX2/MX3/TRS/HT BLK
16	23959	1	PANEL- HIGH RISE LEFT DGRY
15	23960	1	PANEL- HIGH RISE REAR DGRY
14	23958	1	PANEL- HIGH RISE RIGHT DGRY
13	22209	1	HOOD- PAPERGRD 3 ROLL DGRY
	20848	1	HDWE, HIGH RISE
12	20806	1	FRAME, PROP HIGH RISE
11	20797	1	FLOOR, HIGH RISE
10	23963	1	DOOR ASSY- HIGH RISE DGRY
9	20813	2	CASTER, 2 X 6 RIGID HIGH RISE
8	20812	2	CASTER, 2 X 6 SWIVEL HIGH RISE
7	20808	1	BRACE, DOOR FRAME HIGH RISE
6	20851	2	ANGLE, 67 VERT HIGH RISE REAR
5	20850	1	ANGLE, 67 VERT HIGH RISE HASP
4	20849	1	ANGLE, 51-1/2 HOR HIGH RISE RH
3	20800	1	ANGLE, 67 VERT HIGH RISE HINGE
2	20799	1	ANGLE, 30 HORIZ HIGH RISE
1	20798	1	ANGLE, 51-1/2 HOR HIGH RISE LH
ITEM	PART#	QTY	DESCRIPTION

# DIRECTIONS

## 1. ATTACH FLOOR SUPPORT BRACKETS AND CASTER.

**ATTACH #18 SUPPORTS:** to #11 Floor with #39 Rivets on top of floor and #50 Washers on bottom of support, as shown below.

**NOTE:** *Clamping Supports to floor prior to riveting may be needed.*

**ATTACH #8 CASTERS:** to front holes of floor using #22 Bolts, #51 Washers and #36 Nuts. Place #37 Plates in between floor and caster. as shown below.

**ATTACH #9 CASTERS:** Repeat process for attaching #8 CASTERS but use back holes in floor.

**NOTE:** *Swivel Casters go on the front, Rigid Casters on rear.*

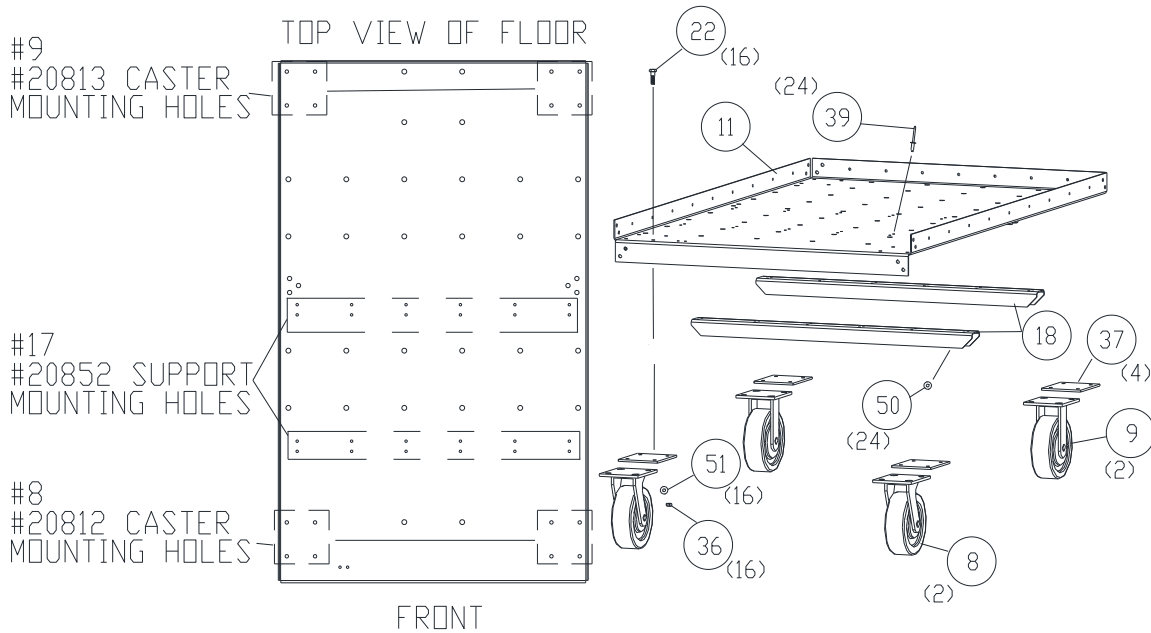

## 2. ATTACH #47 STRIP- 1in ANTISLIP as shown:

**NOTE:** *Strips must be placed on front end.*

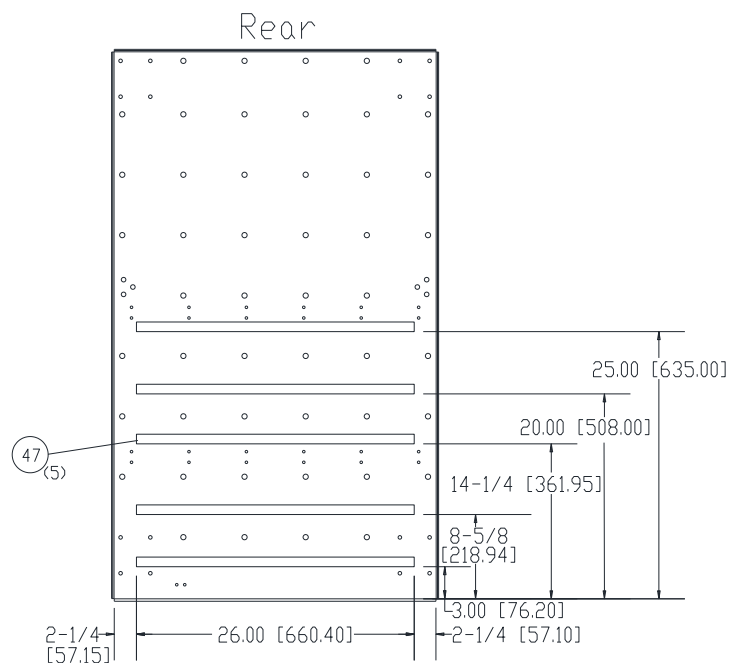

### 3. ATTACH VERTICAL AND HORIZONTAL ANGLES.

**NOTE:** Angles are different, look for hole locations on drawing below.

Fasten **#5** 67" Angle in front, **#6** 67" Angle in back to **#4** 51-1/2" Angle with **#23** Bolts and **#34** Nuts as shown. see notes below for Angle fastening locations.

**NOTE:** Do not tighten nuts on bolts at this time.

Repeat step above on opposite side.

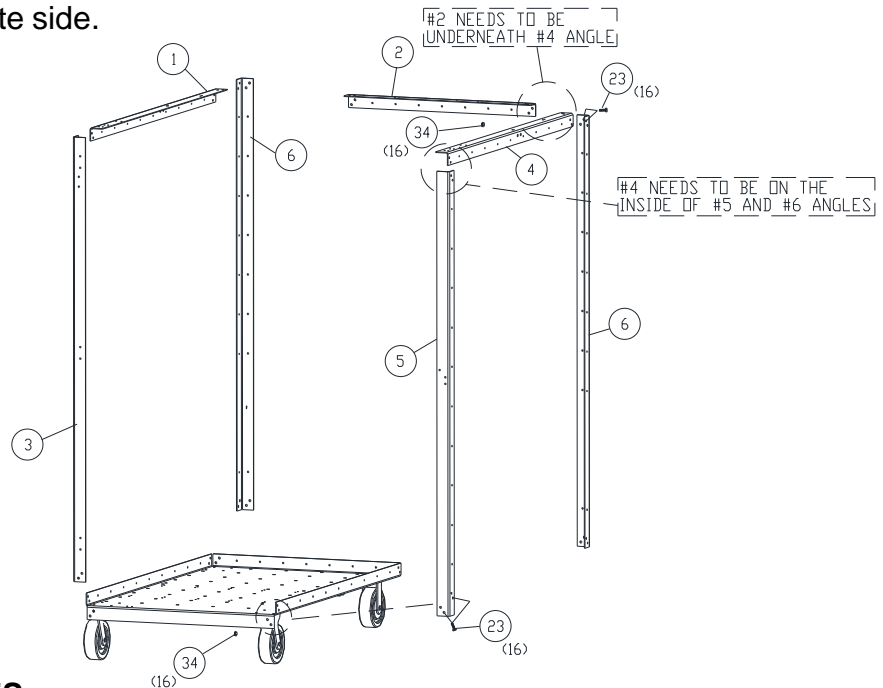

### 4. ATTACH PANELS TO ANGLES.

**FASTEN #15 LEFT PANEL** first to the left side of unit with panel on the inside of angles so the textured side is on the outside of the toilet. *Note that the Left Panel has (4) pre-drilled holes for mounting the urinal, which are towards the front of the unit.*

Fasten with **#38** Rivets and **#50** Washers as shown. Rivet each corner then finish riveting the panel to angles & floor.

Repeat step on back and right-side panels.

**NOTE:** The bottom of Rear Panel does not have holes where the tank fits in unit.

### 5. FASTEN POCKET HANDLES TO PANEL HOLES.

Using **#38** Rivets & **#50** Washers fasten Handle to Panels as shown. Repeat on Right Panel.

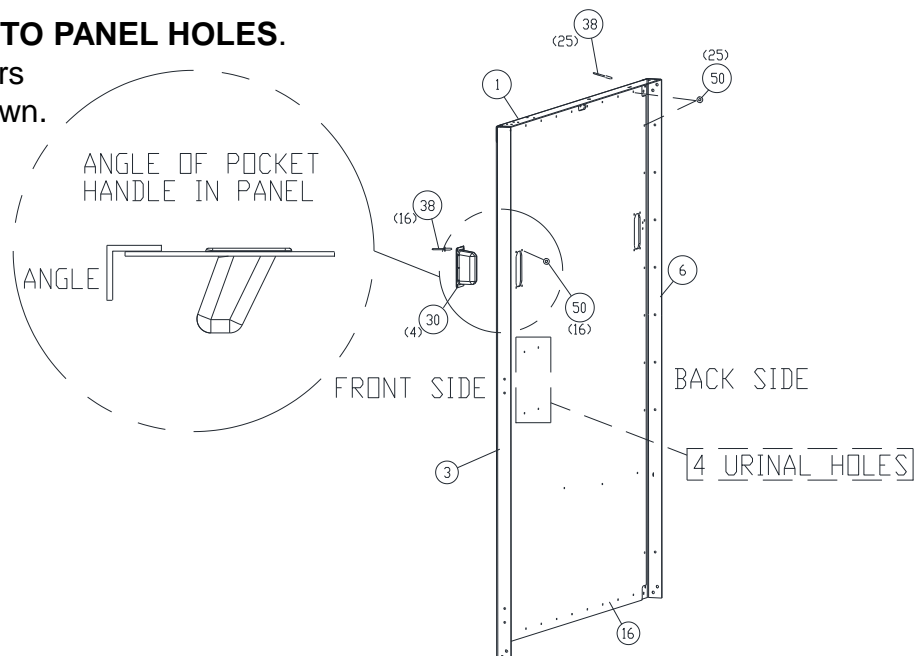

## 6. FASTEN PROP BRACKET AND FRAME.

**ATTACH #25** Bracket to Angles with **#39** Rivets and **#50** washers as shown.

Slide **#48** tube over **#12** Frame on right side. Bolt **#12** Frame to **#25** Brackets with **#24** Bolt and **#35** Nut as shown. **NOTE: Do not over tighten, allow Prop Frame to tilt back but there must be some resistance, so it will not fall.**

Place **#28** decal on **#12** frame as shown.

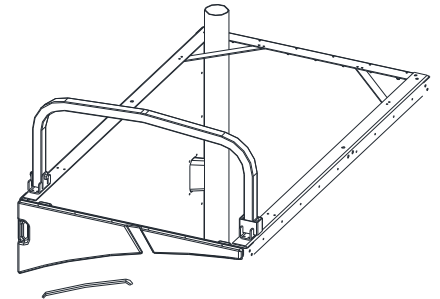
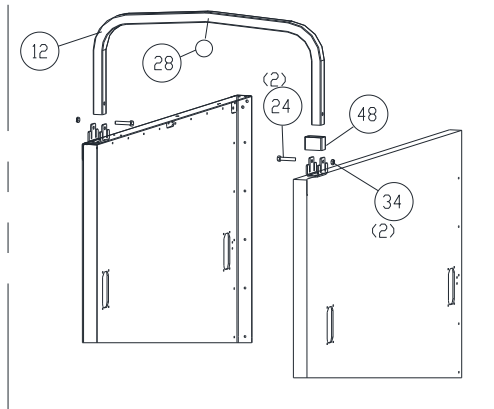
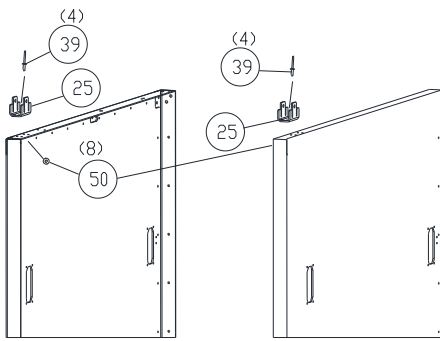

## 7. FASTEN CORNER GUSSETS.

Fasten **#29** gussets under rear corner angles with **#39** Rivets and **#50** Washers as shown.

Repeat step on opposite corner.

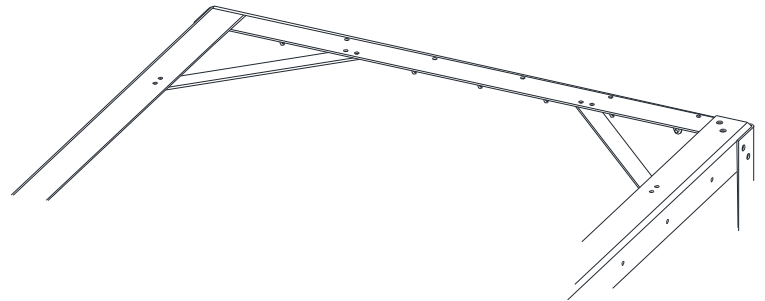
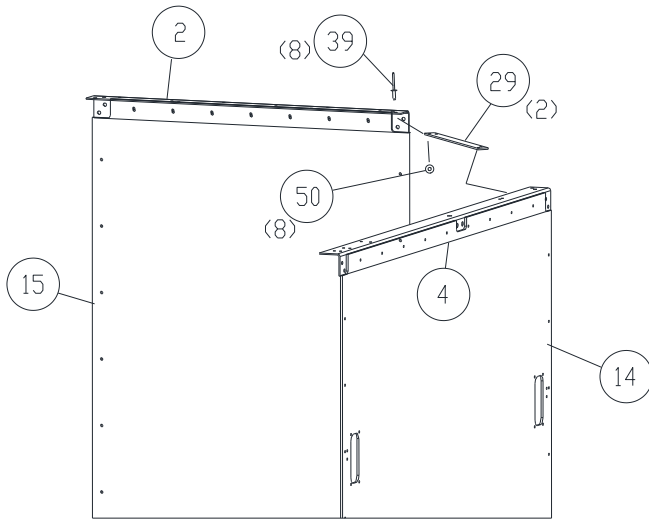

## 8. TIGHTEN ALL BOLTS AND NUTS IN ANGLES TO FLOOR, USE THE 7/16" SOCKET AND WRENCH.

**9. INSTALL TANK AND TOILET SEAT IN REAR OF TOILET.**

Slide **#19** Tank into back of toilet, fasten **#17** Toilet Seat to Tank. Transfer drill through holes in panels (2 per panel) into **#19** Tank.

Fasten panels to tank with **#42** Rivets and **#50** Washers with rivets on outside of toilet and washers on the inside of the tank.

Install the **#21** Vent-pipe. Slide Vent Pipe between gusset and angles in top rear left corner of unit then slide Vent-pipe into hole in Tank. Note the top of the Vent-pipe should be 4.50" from top surface of horizontal angles. fasten with vent pipe to tank with **#43** Screw, use 3/8" nut driver bit and drill.

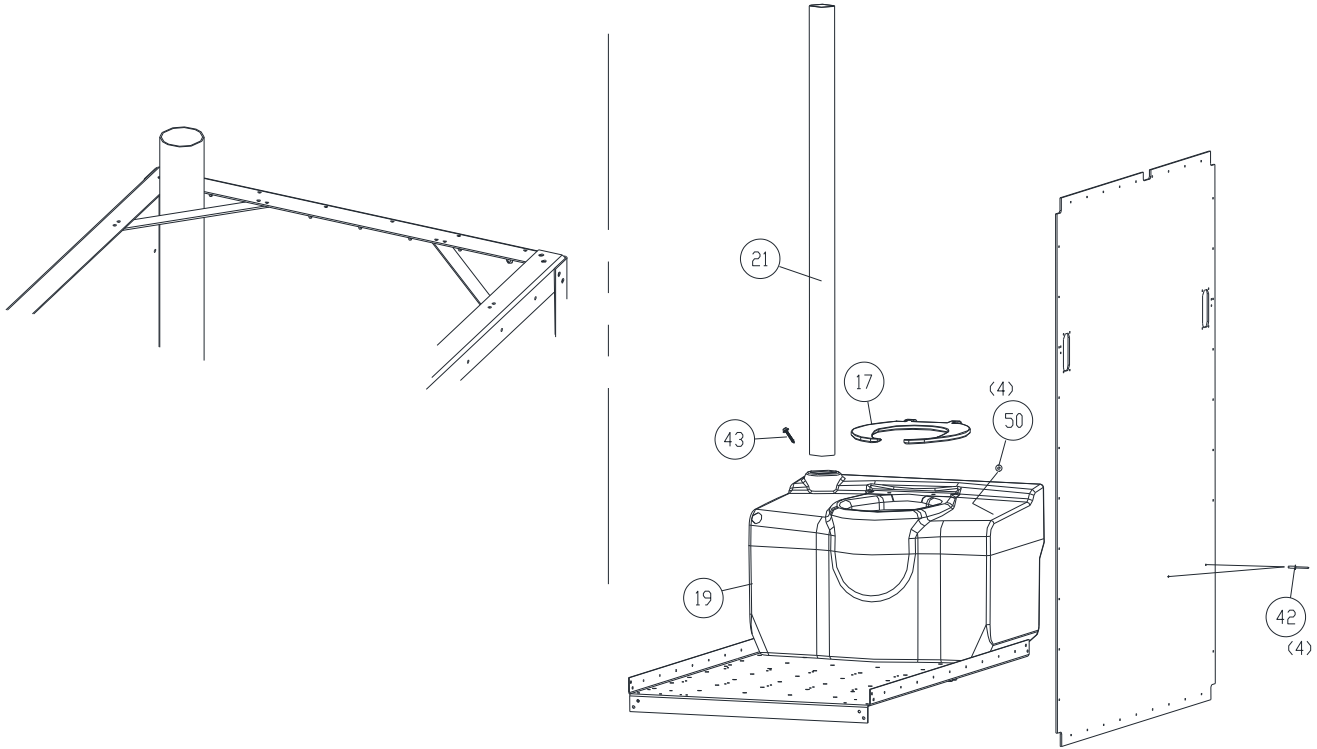

**10. TIGHTEN ALL REMAINING BOLTS AND NUTS TO THE TOP ANGLES AT THIS TIME USE 7/16" SOCKET AND WRENCH.**

**11. INSTALL BRACE DOOR FRAME**

Rivet bottom of **#7** Brace to top of floor, see floor view below for hole location, use **#40** Rivets and **#50** Washers as shown.

Rivet top of **#7** Brace to left side panel. using **#40** Rivets and **#50** Washers as shown.

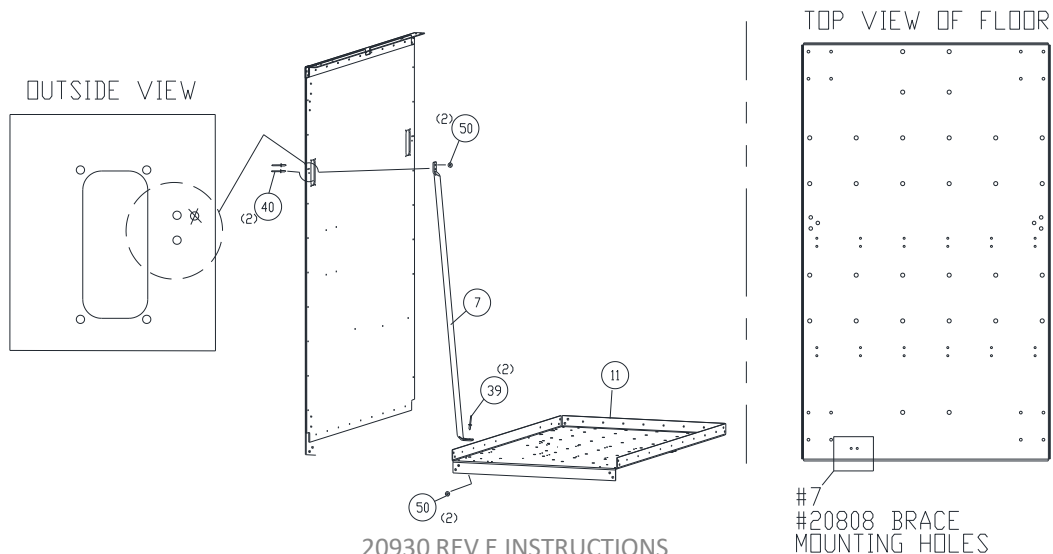



## 12. INSTALL URINAL.

Press **#33** Hose onto **#20** Urinal and fasten with **#26** Clamp. Place hose end into urinal hole in waste tank (top left corner of tank).

Rivet Urinal to left panel, use holes in panel as shown. Rivet the top holes first with **#42** Rivets from the outside and **#50** Washers on the inside. Fasten the bottom holes with **#42** Rivets and **#49** Rubber washer on the inside and **#50** Washer on the outside.

Place **#27** Clamp insulated over Urinal hose and fasten with **#38** Rivet from the outside and **#50** Washer on the inside as shown. *Note the rivet is below hose.*

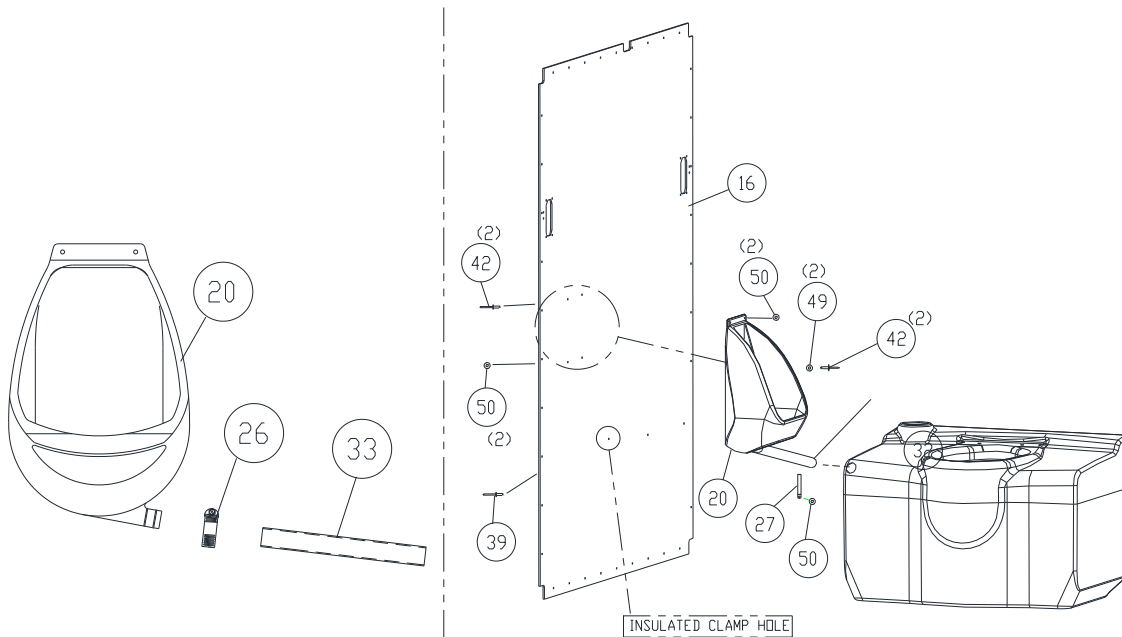

## 13. FASTEN LATCH STOP SPACER AND HASP TO VERTICAL ANGLE.

Place **#45** Spacer on inside of **#5** Vertical hasp angle and fasten with **#38** Rivet from the outside.

Rivet the **#32** Hasp to angle with **#39** Rivets (through hasp then angle) and **#50** Washers (on inside of toilet) as shown.

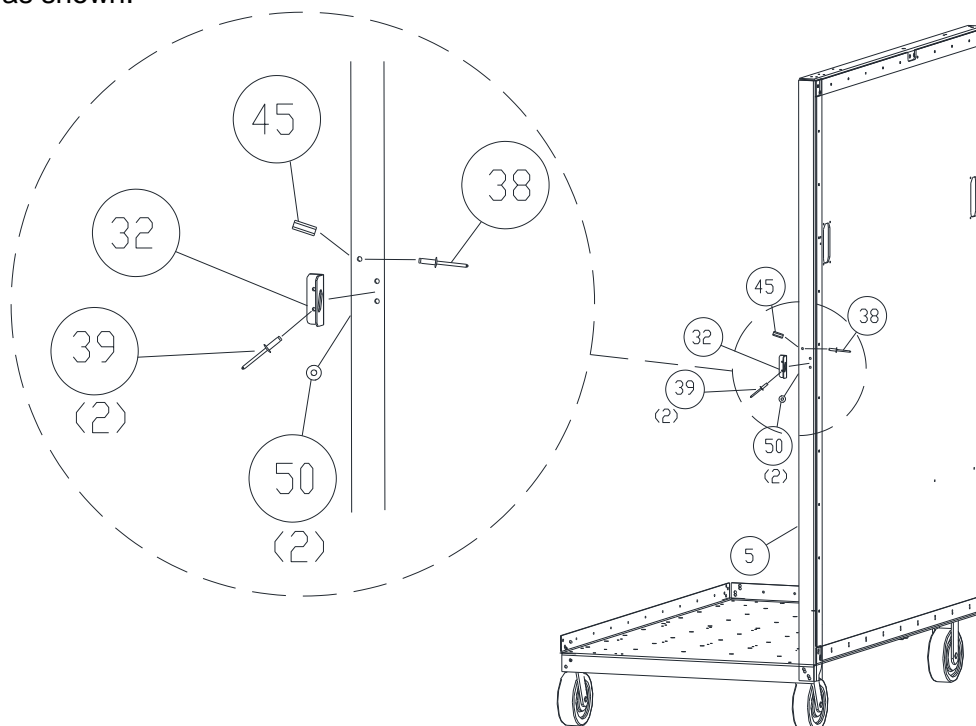

#### 14. FASTEN DOOR ASSY TO ANGLE.

Rivet the #10 Door assembly to angle using #39 Rivet (through hinge then angle) and #50 Washer (on inside of toilet) as shown. Repeat on remaining hinges.

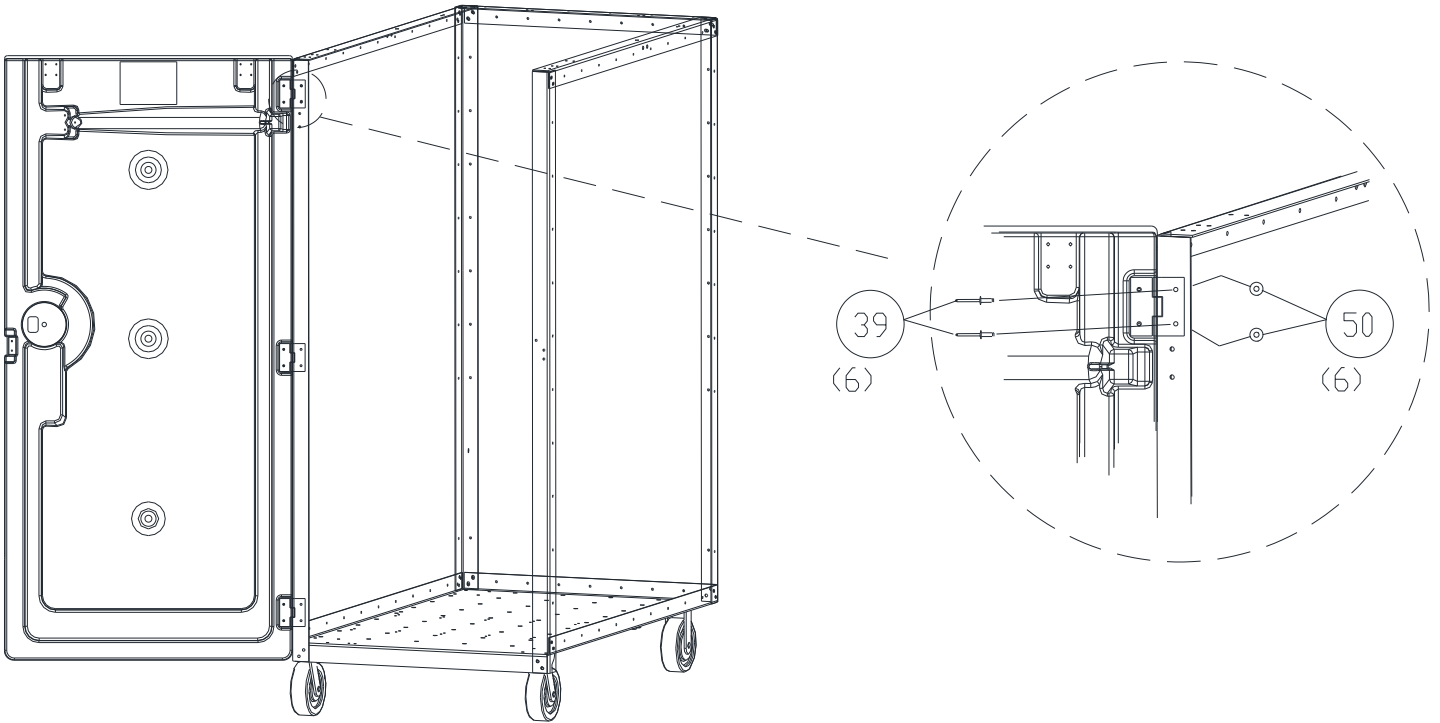

#### 15. FASTEN SPACER AND CABLE ANCHOR TO ANGLE.

Place the #44 Spacer under the Cable anchor bracket. Insert (2) #41 Rivet through both holes in Bracket and through Spacer. Attach to holes in angle below top hinge with #50 Washers on outside of angle. **NOTE:** Hold door part way open to place washers on rivets.

Fasten spring anchor to door with #38 rivets.

**NOTE:** Pull bracket into position on door and insert rivets through bracket into holes in door

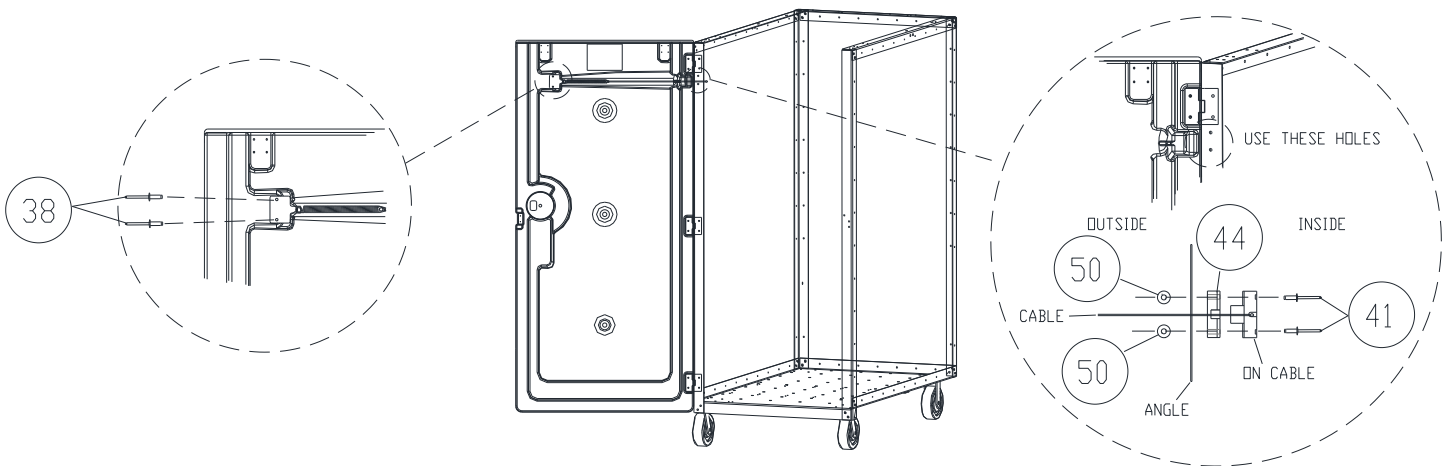

## 16. INSTALLATION OF 3 ROLL PAPERGUARD.

Locate Paperguard #13 on left panel, as shown, and mark locations of holes through the (4) holes inside of the paperguard. Drill at the marked locations with a 1/4" drill bit. Fasten Paperguard hood with the #42 Rivets from the outside and #50 Washers on the inside of the unit. place #46 Spindle through Paperguard.

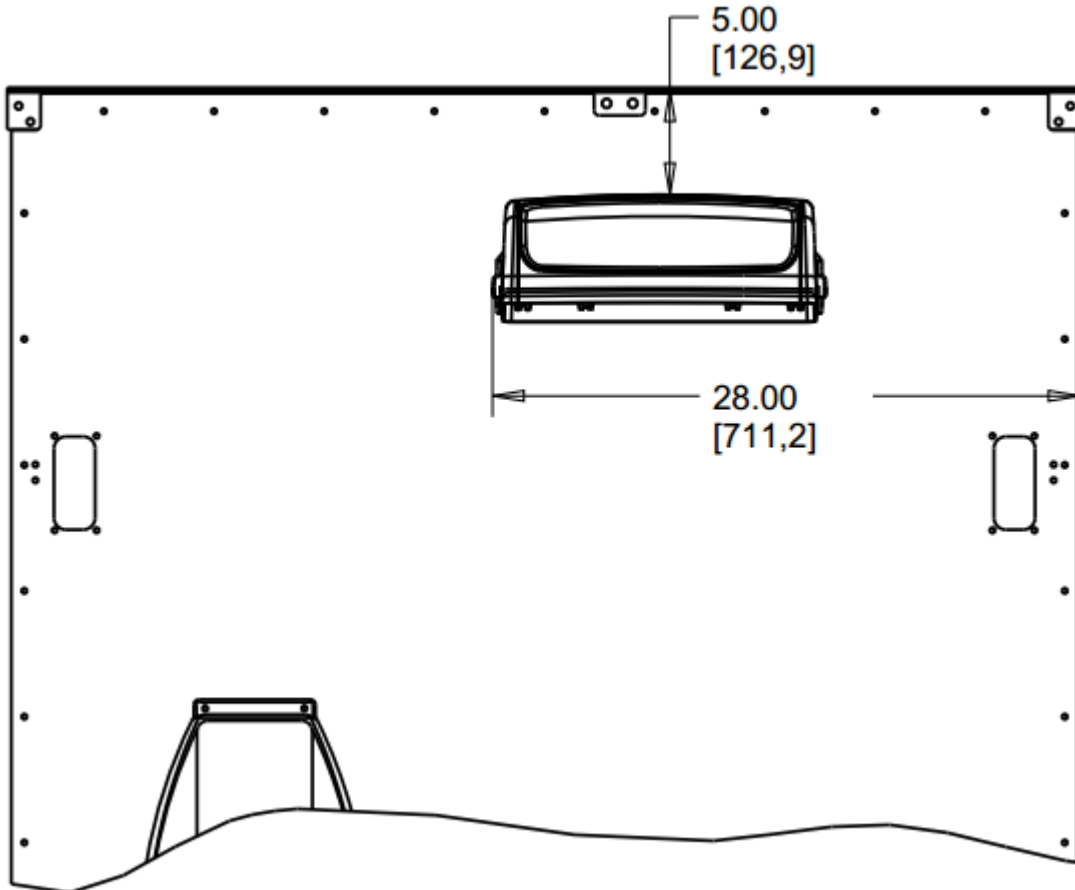

2530 Xenium Lane North, Minneapolis, MN 55441  
Telephone: 763-553-1900 Fax: 763-553-1905  
800-328-3332 / [www.satelliteindustries.com](http://www.satelliteindustries.com)