

**11EER W18AB-W36AB Series WALL-MOUNT™**  
**11EER W18LB-W36LB Series WALL-MOUNT™**

The Bard Wall-Mount Air Conditioner is a self contained energy efficient system, which is designed to offer maximum indoor comfort at a minimal cost without using valuable indoor floor space or outside ground space. This unit is the ideal product for versatile applications such as: new construction, modular offices, school modernization, telecommunication structures, portable structures, correctional facilities and many more. Factory or field installed accessories are available to meet specific job requirements for your unique application.

- Complies with efficiency requirements of ASHRAE/IESNA 90.1-2016
- Certified to ASNI/ARI Standard 390-2003 for SPVU (Single Package Vertical Units)
- Intertek ETL Listed to Standard for Safety Heating and Cooling Equipment ANSI/UL 1995/CSA 22.2 No. 236-05 Fourth Edition
- Commercial Product - Not intended for residential application
- Bard is an ISO 9001:2015 Certified Manufacturer
- The AHRI Certified® mark indicates Bard Manufacturing Company participation in the AHRI Certification program. For verification of individual certified products, go to [www.ahridirectory.org](http://www.ahridirectory.org).



[BARDHVAC.COM](http://BARDHVAC.COM)

FORM NO. S3573-0720



///// WALL-MOUNT NOMENCLATURE

**W 3 6 A B - A 0 Z X P X X X X**

**UNIT SERIES**  
Wall-Mount

**NOMINAL CAPACITY**  
18- 1.5 Ton  
24 - 2 Ton  
30 - 2.5 Ton  
36 - 3 Ton

**CONTROLS LOCATION**  
A - Right Side AC  
L - Left Side AC

**REVISION**  
B Revision Level

**PLACEHOLDER**  
D - Dehumidification (W30 thru W36 )

**VOLTAGE**  
A - 230 Volt 1 Phase 60 Hz  
B - 230 Volt 3 Phase 60 Hz  
C - 460 Volt 3 Phase 60 Hz

**ELECTRIC HEAT**  
00 - 0Kw with Lug Connection  
0Z - 0Kw with Circuit Breaker  
05 thru 15kw with Circuit Breaker  
*See Electrical Specs for further details*

**VENT PACKAGE**  
X - Fresh Air Damper  
A - Fresh Air Damper w/Exhaust  
B - Blank Off Plate  
M - Comm. Ventilator, ON/OFF  
V - Comm. Ventilator, 0-10V variable  
D - Economizer, 0-10V No Controls  
S - Partial Flow Economizer, JADE  
Y - Full Flow Economizer, JADE Dry Bulb  
Z - Full Flow Economizer, JADE Enthalpy Bulb  
R - Energy Recovery Vent

**FILTER**  
X - 1" MERV2 Disposable Filter  
W - 1" MERV2 Permanent Filter  
P - 2" MERV8 Disposable Filter  
M - 2" MERV11 Disposable Filter  
N - 2" MERV13 Disposable Filter

**COLOR AND CABINET FINISH**  
X - Beige baked enamel finish  
1 - White baked enamel finish  
4 - Buckeye Gray baked enamel finish  
5 - Desert Brown baked enamel finish  
8 - Dark Bronze baked enamel finish  
S - Stainless Steel  
A - Aluminum

**PLACEHOLDER**  
"X"for future use

**COIL & COATING OPTIONS**  
X - Standard  
1 - Phenolic Coated Evaporator  
2 - Phenolic Coated Condenser  
3 - Phenolic Coated Evaporator and Condenser  
4 - Coated Coils and condenser section  
5 - Coated coils, inside and out side of unit

**ACCESSORIES AND CONTROLS OPTIONS**  
X - Standard controls  
E - Low Ambient Control (LAC)  
F - LAC, Alarm Relay (ALR), Filter Press. Switch (FPS)  
J - LAC and Alarm Relay (ALR)  
K - LAC and PTCR Start Kit  
M - LAC, ALR, and PTCR Start Kit  
V - DDC Control Sensor kit with 10K Discharge air sensor, indoor blower airflow sensor, compressor current sensor, filter press. switch, LAC, ALR.

## ENGINEERED FEATURES

**NEW! EXCLUSIVE \*Non-Fiberglass Foil Faced Insulation:** Environmentally friendly high “R” value non-fiberglass insulation that is made with recycled denim and cotton materials used with a FSK foil face that is both durable and cleanable.

**Durable Cabinet Construction:** Multiple cabinet construction options are available for different outdoor conditions. Optional cabinet coatings may be ordered for extreme outdoor environments.

**Easy Filter Access:** A separate filter door is provided for ease of filter access during routine unit maintenance. 1” and 2” filters are available with a rating of up to MERV13.

**Field or Factory Installed Vents:** Multiple ventilation options are available as easily installed kits with electrical plugs, or Factory installed options that can be removed for service.

**Electric Strip Heat:** Reliable, comfortable heater packages feature an automatic limit and thermal cut-off safety control. Heater packages can be factory or field installed.

**Built-in Circuit Breakers:** Standard on all electric heat versions of single (240/220 volt) and three phase (220/200 volt) equipment. Toggle disconnects are standard on all electric heat versions of three phase (415/380 volt) equipment.

**Reliable, Easy-to-Use Controls:** Easily accessible through left or right control panel locations. A lockable hinged access cover to circuit protection is provided. Phase rotation monitor is standard on all 3 phase models. Adjustable compressor on/off delay timer (CCM) with diagnostic lights is standard on all models.

**Green Fin Hydrophilic Evaporator Coil:** Green fin stock enhances coil wettability to help prevent mold growth, aid with condensate drainage, and provide a limited amount of protection to corrosive particulates in the airstream.

**\*Balanced Climate™ Technology (patent pending):** High latent capacity humidity & sound reduction removes up to 35% more humidity than any other on the market with the use of a 2 stage thermostat or controlling device. Bard Balanced Climate™ innovation comes standard on all models.

**Optional Mechanical Dehumidification:** Models are available with hot gas reheat dehumidification for energy efficient humidity removal. Electronic Expansion Valves are standard for all dehumidification models.

**ECM Indoor Motor Technology:** 5 speed dual shaft motor provides quiet airflow operation when used with a twin blower assembly. Motor overload protection standard on all models.

**Enclosed Condenser Motor:** An enclosed casing condenser motor with ball bearings is used for reliable operation and extended motor life. Enclosed condenser motors are standard on all units.

**High Efficiency Cooling:** Scroll compressors for quiet, efficient cooling. Designed with R-410A (HFC) non-ozone depleting refrigerant in compliance with the Montreal protocol and 2010 EPA requirements. A liquid line filter-drier to protect the system from moisture is standard on all units.

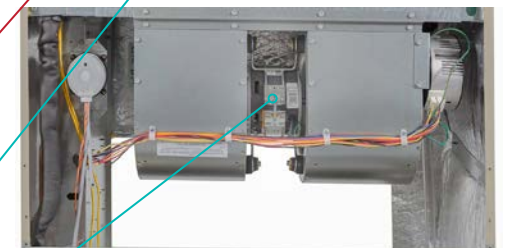
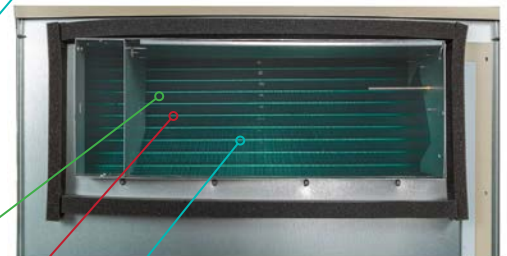
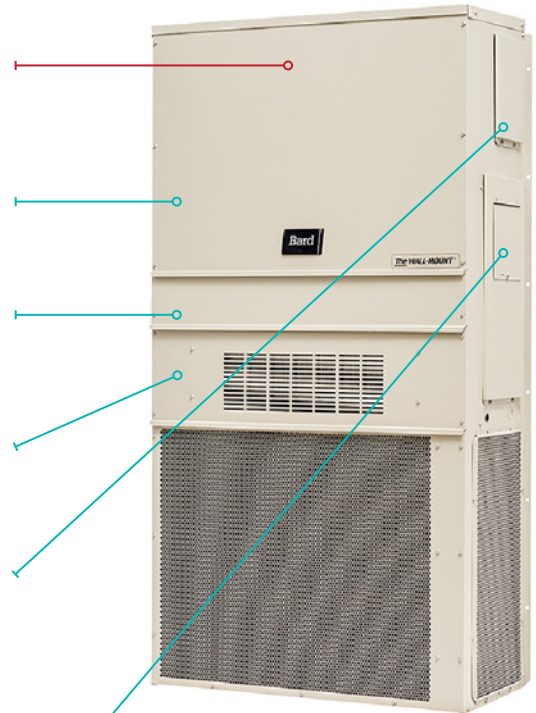

## UNIT MODES OF OPERATION

**Cooling Operation:** The Bard WA and WL Series WALL MOUNT products offer single stage cooling operation using R410A refrigerant. Copper tube/Aluminum green fin coils are used to provide high efficiency and easy serviceability. Scroll compressor technology delivers years of quiet, reliable operation.



**Heating Operation:** The Bard WA and WL Series WALL MOUNT products offer optional single or two stage heating operation using resistance heaters. Circuit breaker disconnect protection is standard in all units equipped with electric heat.



**Mechanical Dehumidification Operation:** The Bard W30AB and W36AB Series WALL MOUNT products offer optional dehumidification operation that removes moisture while running at a quiet lower blower speed. A three-way valve, reheat coil, and electronic expansion valve (EEV) are standard with all models. The dehumidification circuit incorporates an independent heat exchanger coil in the supply air stream. The coil reheats the supply air after it passes over the cooling coil without requiring the electric resistance heater to be used for reheat purposes. This results in very high mechanical dehumidification capability from the air conditioner on demand without using electric resistance reheat. The mechanical dehumidification option is available in right-hand control panel models only.



**Ventilation Operation:** The Bard WA and WL Series WALL MOUNT products offer optional ventilation operation that brings outdoor air into the structure. Vent options can be factory or field installed, and can be used to bring in outdoor air for occupants, save energy by using outdoor air for free cooling, or positively pressurize a structure. Exhaust air options allow room air to be vented outdoors when fresh air is being brought into the structure. Energy recovery options are also available for occupied structures which condition the air being brought in to save energy when ventilation is necessary regardless of outdoor temperature.



**Balanced Climate™ Operation:** The Bard WA and WL Series WALL MOUNT products offer an enhanced latent capacity stage that can be controlled by a two stage cooling thermostat. During the first cooling stage (Balanced Climate Mode), the unit will increase the amount of moisture removed during compressor operation. The second stage (standard mode) of cooling increases the sensible cooling capacity to increase the amount of heat removed from the structure during compressor operation. Available in high supply static applications. In order for Balanced Climate to be used, a jumper must be removed between Y1 and Y2. Unit is shipped with jumper in place and Balanced Climate disabled.



## ADVANCED FEATURE DESCRIPTIONS

**ECM Indoor Blower Motor:** Energy efficient indoor blower motors use EC constant torque technology with 5 pre-programmed speeds. By selecting the needed speed, the WALL MOUNT product can reduce or increase airflow. A NEMA48® frame enclosure is used. A medium and high speed tap can be user selected to offer the maximum CFM possible with the blower assembly.

- Efficient 5 speed ECM constant torque motor. 24VAC power used for speed selection.
- Fully potted electronic control module for moisture protection.
- 6000V surge protection.
- Dual shaft design with open air over (OAO) enclosure.



**Outdoor Fan Motor:** Outdoor fan motors use ball bearing construction and are fully enclosed for increased life expectancy.

- Single speed PSC motor.
- Totally enclosed motor housing protects motor windings and internal components from corrosion.
- Ball bearing design reduces motor wear from “windmill” affect when not in operation.



**Non Fiberglass Cabinet Insulation:** The WA and WL MOUNT products use advanced non-fiberglass insulation that is made with recycled denim materials. High "R" value, enhanced sound absorption, and reduced delamination are some of the features of this revolutionary product.

- Easy to clean and damage resistant Foil FSK Facing.
- Fiberglass and Formaldehyde free.
- Meets ASTM E84, UL 723, NFPA 90A and 90B Standards.
- Thermal performance ASTM C518 k=.27@1" & 900gsm



## ////// CAPACITY AND EFFICIENCY RATINGS

MODELS	W18AB W18LB	W24AB W24LB	W30AB W30LB	W36AB W36LB
Cooling Capacity BTUH ①	18,000	24,000	29,200	35,200
EER	11.3	11.2	11.0	11.0

① Capacity is certified in accordance with ANSI/ARI Standard 390-2003.

② EER = Energy Efficiency Ratio and is certified in accordance with ANSI/ARI Standard 390-2003.  
All ratings based on fresh air intake being 100% closed (no outside air introduction).

## ////// SPECIFICATIONS 1-1/2 TON THROUGH 3 TON

MODELS	W18AB-A W18LB-A	W24AB-A W24LB-A	W24AB-B W24LB-B	W24AB-C	W30AB-A W30LB-A	W30AB-B W30LB-B	W30AB-C W30LB-C	W36AB-A W36LB-A	W36AB-B W36LB-B	W36AB-C W36LB-C
<b>Electrical Rating – 60 Hz</b>	230/208 - 1	230/208 - 1	230/208 - 3	460 - 3	230/208 - 1	230/208 - 3	460 - 3	230/208 - 1	230/208 - 3	460 - 3
Operating Voltage Range	197-253	197-253	197-253	414-506	197-253	197-253	414-506	197-253	197-253	414-506
<b>Compressor--Circuit A</b>										
Voltage	230/208	230/208	230/208	460	230/208	230/208	460	230/208	230/208	460
Rated Load Amps	6.0/6.9	8.3/9.4	5.0/5.7	2.7	9.6/10.9	6.1/6.9	3.3	11.4/13.3	7.1/8.3	4.7
Branch Circuit Selection Current	9.0	12.9	7.7	3.6	14.2	9.0	4.2	16.7	10.5	5.8
Lock Rotor Amps	48/48	58.3/58.3	55.4/55.4	28	73/73	58/58	28	79/79	73/73	38
Compressor Type	Scroll	Scroll	Scroll	Scroll	Scroll	Scroll	Scroll	Scroll	Scroll	Scroll
<b>Fan Motor &amp; Condenser</b>										
Fan Motor--HP--RPM	1/5 - 1090	1/5 - 1090	1/5 - 1090	1/5 - 1075	1/5 - 1075	1/5 - 1075	1/5 - 1075	1/5 - 1075	1/5 - 1075	1/5 - 1075
Fan Motor--Amps	1.1	1.1	1.1	0.6	1.2	1.2	0.6	1.2	1.2	0.6
Fan--DIA/CFM	18" - 1800	18" - 1800	18" - 1800	18" - 1800	20" - 2400	20" - 2400	20" - 2400	20" - 2200	20" - 2200	20" - 2200
<b>Blower Motor &amp; Evap.</b>										
Blower Motor--HP-SPD	1/3-5	1/3-5	1/3-5	1/3-5	1/2-5	1/2-5	1/2-5	1/2-5	1/2-5	1/2-5
Blower Motor--Amps	0.7	0.7	0.7	.8	1.4	1.4	1.1	2.3	2.3	1.0
Motor Type	ECM	ECM	ECM	ECM	ECM	ECM	ECM	ECM	ECM	ECM
CFM Cooling & E.S.P. w/Filter (Rated-Wet Coil)	600 - .1	800 - .1	800 - .1	800 - .1	950 - .15	950 - .15	950 - .15	1150 - .15	1150 - .15	1150 - .15
Filter Sizes (inches) STD.	16x25x1	16x25x1	16x25x1	16x25x1	16x30x1	16x30x1	16x30x1	16x30x1	16x30x1	16x30x1
<b>Basic Unit Weight-LBS.</b>										
Barometric Fresh Air Damper (X)	4.0	4.0	4.0	4.0	5.0	5.0	5.0	5.0	5.0	5.0
Barometric Damper w/ Exhaust (A)	8.0	8.0	8.0	8.0	9.0	9.0	9.0	9.0	9.0	9.0
Blank-Off Plate (B)	1.0	1.0	1.0	1.0	1.0	1.0	1.0	1.0	1.0	1.0
Commercial Room Ventilator (M, V)	31.0	31.0	31.0	31.0	35.0	35.0	35.0	35.0	35.0	35.0
Economizer (D, S, Z)	37.0	37.0	37.0	37.0	37.0	37.0	37.0	37.0	37.0	37.0
Energy Recovery Ventilator (R)	54.0	54.0	54.0	54.0	65.0	65.0	65.0	65.0	65.0	65.0

## ////// OPTIONAL SHIPPING CRATES

Optional crates are available to help protect your valuable WALL MOUNT investment during shipping. Constructed from OSB sheathing with steel corner posts, and sized for standard truck transportation. Treated for pests in accordance with the International Plant Protection Convention, Publication 15, Annex 1. Packaging is acceptable for international shipments.

CRATE NO.	UNITS USING CRATE	DESCRIPTION
8620-263	W18A, W18L, W24A, W24L	Standard Unit Crate
8620-275	W18A, W18L, W24A, W24L	Units with "Y" or "Z" Economizer With Factory Installed 7" Hood
8620-262	W30A, W30L, W36A, W36L	Standard Unit Crate
8620-276	W30A, W30L, W36A, W36L	Units with "Y" or "Z" Economizer With Factory Installed 7" Hood

////// **COOLING APPLICATION DATA - OUTDOOR TEMPERATURE** ① ②

MODEL	RETURN AIR (DB/WB)	COOLING CAPACITY	75°F	80°F	85°F	90°F	95°F	100°F	105°F	110°F	115°F	120°F	125°F	131°F
W18	75/62	Total Cooling	19800	18700	17600	16700	15700	15000	14200	13600	13000	12500	12000	11500
		Sensible Cooling	15000	14600	14200	13800	13400	13100	12800	12500	12200	12000	11700	11500
	80/67	Total Cooling	21100	20300	19500	18800	18000	17400	16700	16200	15600	15100	14600	14000
		Sensible Cooling	14500	14300	14000	13800	13500	13300	13100	12900	12700	12500	12300	12100
	85/72	Total Cooling	25200	23800	22400	21300	20000	19100	18000	17300	16400	15700	15100	14300
		Sensible Cooling	14900	14600	14100	13700	13300	12900	12500	12100	11700	11300	10900	10500
W24	75/62	Total Cooling	25000	24000	23000	22000	20900	20000	19000	18100	17100	16200	15200	14000
		Sensible Cooling	18400	18300	18200	18000	17800	17400	17100	16800	16300	15800	15200	14000
	80/67	Total Cooling	26600	26100	25500	24800	24000	23300	22400	21500	20600	19600	18500	17100
		Sensible Cooling	17800	17900	18000	18000	17900	17700	17500	17300	16900	16500	16000	15400
	85/72	Total Cooling	31700	30500	29300	28000	26700	25500	24200	22900	21700	20400	19100	17400
		Sensible Cooling	18300	18200	18100	17900	17600	17200	16700	16300	15600	14900	14200	13300
W30	75/62	Total Cooling	30800	29300	28000	26700	25500	24300	23200	22100	21000	19900	18900	17700
		Sensible Cooling	23500	23000	22400	21900	21400	20900	20400	20000	19400	19000	18600	17700
	80/67	Total Cooling	32800	31900	31100	30200	29200	28300	27300	26300	25200	24100	23000	N/A
		Sensible Cooling	22800	22500	22200	21900	21600	21200	20900	20600	20200	19900	19500	N/A
	85/72	Total Cooling	39100	37300	35700	34100	32500	31000	29500	28000	26500	25100	23700	N/A
		Sensible Cooling	23400	22900	22300	21800	21200	20500	19900	19300	18600	18000	17300	N/A
W36	75/62	Total Cooling	37300	35500	33900	32200	30700	29200	27800	26400	25100	23900	22600	21200
		Sensible Cooling	29200	28400	27600	26800	26100	25500	24800	24200	23700	23100	22600	21200
	80/67	Total Cooling	39800	38700	37600	36400	35200	34000	32800	31500	30200	28900	27500	25900
		Sensible Cooling	28300	27800	27300	26800	26300	25900	25400	25000	24600	24200	23800	23400
	85/72	Total Cooling	47400	45300	43200	41100	39100	37200	35400	33500	31800	30100	28300	N/A
		Sensible Cooling	29000	28200	27500	26600	25800	25100	24200	23500	22700	21900	21100	N/A

- ① Low ambient control allows for compressor operation down to 0°F.
- ② Outdoor temperatures shown are measured at the condenser section air inlet.
- ③ Return air temperature °F.

CAPACITY MULTIPLIER FACTORS			
% of Rated Airflow	-10	Rated	+10
<b>Total BTUH</b>	0.975	1.0	1.02
<b>Sensible BTUH</b>	0.950	1.0	1.05

////// **UNIT CHARGE RATES**

UNIT	STD. UNIT - LBS.	DEHUM. UNITS - LBS.
W18AB/LB - 11 EER Right & Left A/C	3.50	N/A
W24AB/LB - 11 EER Right & Left A/C	4.25	N/A
W30AB/LB - 11 EER Right & Left A/C	4.125	4.25
W36AB/LB- 11 EER Right & Left A/C	4.50	4.50

/////// **BALANCED CLIMATE APPLICATION DATA (OPTIONAL, REQUIRES THERMOSTAT WITH 2 COOLING STAGES)**

MODEL	RETURN AIR (DB/WB)	COOLING CAPACITY	75°F	80°F	85°F	90°F	95°F	100°F	105°F	110°F	115°F	120°F	125°F	131°F <sup>Ⓢ</sup>
<b>W18</b>	75/62	Total Cooling	18700	17900	17200	16500	15700	15000	14300	13500	12700	12000	11200	10300
		Sensible Cooling	12900	12700	12400	11900	11600	11300	11000	10600	10200	9900	9400	9000
		Latent Cooling	5800	5200	4800	4600	4100	3700	3300	2900	2500	2100	1800	1300
		% Latent Increase	17%	21%	29%	37%	44%	49%	58%	62%	68%	76%	83%	100%
		Lbs. H2O per Hr.	5.472	4.906	4.528	4.34	3.868	3.491	3.113	2.736	2.358	1.981	1.698	1.226
	80/67	Total Cooling	19900	19500	19100	18600	18000	17400	16800	16100	15300	14500	13600	12500
		Sensible Cooling	12500	12400	12200	11900	11700	11500	11200	10900	10600	10300	9900	9500
		Latent Cooling	7400	7100	6900	6700	6300	5900	5600	5200	4700	4200	3700	3000
		% Latent Increase	11%	15%	20%	25%	29%	31%	36%	37%	38%	38%	38%	37%
Lbs. H2O per Hr.		6.981	6.698	6.509	6.321	5.943	5.566	5.283	4.906	4.434	3.962	3.491	2.83	
85/72	Total Cooling	23700	22800	2200	21000	20000	19100	18200	17200	16100	15100	14000	12800	
	Sensible Cooling	12800	12600	12300	11900	11500	11200	10700	10300	9800	9300	8800	8200	
	Latent Cooling	10900	10200	9700	9100	8500	7900	7500	6900	6300	5800	5200	4600	
	% Latent Increase	6%	10%	14%	16%	21%	22%	27%	25%	25%	24%	19%	17%	
	Lbs. H2O per Hr.	10.8	9.623	9.151	8.585	8.019	7.453	7.075	6.509	5.943	5.472	4.906	4.34	
<b>W24</b>	75/62	Total Cooling	24300	23300	22400	21400	20400	19500	18600	17600	16700	15800	14800	13700
		Sensible Cooling	16900	16600	16200	15800	15400	15000	14600	14100	13700	13200	12800	12200
		Latent Cooling	7400	6700	6200	5600	5000	4500	4000	3500	3000	2600	2000	1500
		% Latent Increase	20%	22%	27%	30%	38%	42%	50%	57%	70%	81%	100%	100%
		Lbs. H2O per Hr.	6.981	6.321	5.849	5.283	4.717	4.245	3.774	3.302	2.83	2.453	1.887	1.415
	80/67	Total Cooling	25900	25400	24800	24100	23400	22700	21900	21000	20100	19100	18000	16700
		Sensible Cooling	16400	16200	16000	15800	15500	15200	14900	14500	14200	13800	13400	12900
		Latent Cooling	9500	9200	8800	8300	7900	7500	7000	6500	5900	5300	4600	3800
		% Latent Increase	14%	16%	18%	19%	23%	25%	29%	32%	37%	40%	46%	55%
Lbs. H2O per Hr.		8.962	8.679	8.302	7.83	7.453	7.075	6.604	6.132	5.566	5	4.34	3.585	
85/72	Total Cooling	30900	29700	28500	27200	26000	24900	23600	22400	21200	19900	18500	17000	
	Sensible Cooling	16800	16500	16100	15700	15200	14700	14200	13600	13100	12500	11900	11100	
	Latent Cooling	14100	13200	12400	11500	10800	10200	9400	8800	8100	7400	6600	5900	
	% Latent Increase	8%	10%	12%	13%	16%	19%	19%	23%	25%	26%	26%	31%	
	Lbs. H2O per Hr.	13.3	12.45	11.7	10.85	10.19	9.623	8.868	8.302	7.642	6.981	6.226	5.566	
<b>W30</b>	75/62	Total Cooling	29100	27800	26700	25600	24400	23400	22300	21300	20300	19300	18300	17100
		Sensible Cooling	20700	20000	19500	19000	18600	18100	17600	17200	16700	16300	15800	15300
		Latent Cooling	8400	7800	7200	6600	5800	5300	4700	4100	3600	3000	2500	1800
		% Latent Increase	13%	19%	22%	27%	29%	36%	40%	49%	56%	70%	88%	100%
		Lbs. H2O per Hr.	7.925	7.358	6.792	6.226	5.472	5	4.434	3.868	3.396	2.83	2.358	1.698
	80/67	Total Cooling	31000	30300	29600	28900	28000	27200	26300	25400	24400	23400	22300	N/A
		Sensible Cooling	20000	19600	19300	19000	18700	18400	18000	17700	17300	17000	16600	N/A
		Latent Cooling	11000	10700	10300	9900	9300	8800	8300	7700	7100	6400	5700	N/A
		% Latent Increase	9%	12%	14%	16%	18%	19%	23%	26%	30%	34%	39%	N/A
Lbs. H2O per Hr.		10.38	10.09	9.717	9.34	8.774	8.302	7.83	7.264	6.698	6.038	5.377	N/A	
85/72	Total Cooling	37000	35500	34000	32700	31100	29800	28400	27100	25700	24300	23000	N/A	
	Sensible Cooling	20500	19900	19400	18900	18400	17800	17200	16600	16000	15400	14700	N/A	
	Latent Cooling	16500	15600	14600	13800	12700	12000	11200	10500	9700	8900	8300	N/A	
	% Latent Increase	5%	8%	8%	11%	11%	13%	14%	17%	19%	20%	23%	N/A	
	Lbs. H2O per Hr.	15.57	14.72	13.77	13.02	11.98	11.32	10.57	9.906	9.151	8.396	7.83	N/A	
<b>W36</b>	75/62	Total Cooling	35200	33600	32000	30500	28900	27600	26300	25000	23800	22600	21400	20100
		Sensible Cooling	24700	23900	23300	22500	21900	21300	20700	20100	19500	18900	18500	17800
		Latent Cooling	10500	9700	8700	8000	7000	6300	5600	4900	4300	3700	2900	2300
		% Latent Increase	23%	27%	28%	33%	34%	41%	46%	55%	67%	78%	100%	100%
		Lbs. H2O per Hr.	9.906	9.151	8.208	7.547	6.604	5.943	5.283	4.623	4.057	3.491	2.736	2.17
	80/67	Total Cooling	37600	36600	35500	34400	33200	32100	31000	29800	28600	27400	26100	24600
		Sensible Cooling	23900	23400	23000	22500	22100	21600	21200	20700	20300	19800	19400	18800
		Latent Cooling	13700	13200	12500	11900	11100	10500	9800	9100	8300	7600	6700	5800
		% Latent Increase	16%	17%	18%	19%	20%	23%	24%	29%	33%	38%	45%	57%
Lbs. H2O per Hr.		12.92	12.45	11.79	11.23	10.47	9.906	9.245	8.585	7.83	7.17	6.321	5.472	
85/72	Total Cooling	44800	42800	40800	38900	36900	35100	33500	31700	30100	28500	26900	N/A	
	Sensible Cooling	24500	23800	23100	22400	21700	20900	20200	19400	18700	17900	17200	N/A	
	Latent Cooling	20300	19000	17700	16500	15200	14200	13300	12300	11400	10600	9700	N/A	
	% Latent Increase	9%	10%	11%	12%	13%	15%	16%	19%	20%	23%	26%	N/A	
	Lbs. H2O per Hr.	19.15	17.92	16.7	15.57	14.34	13.4	12.55	11.6	10.75	10	9.151	N/A	

- ① Low ambient operation disables Balanced Climate Operation.
- ② Outdoor temperatures shown are measured at the condenser section air inlet.
- ③ Return air temperature °F.
- ④ % Latent increase is a comparison to non-Balanced Climate unit operation.
- ⑤ Units with mechanical dehumidification rated to 125°F outdoor temperatures.

CAPACITY MULTIPLIER FACTORS			
% of Rated Airflow	-10	Rated	+10
<b>Total BTUH</b>	0.975	1.0	1.02
<b>Sensible BTUH</b>	0.950	1.0	1.05

///// INDOOR AIRFLOW CFM @ STATIC PRESSURES - EC BLOWER CONSTANT TORQUE MOTOR WITH ADJUSTMENT SPEEDS

ESP	W18 BLOWER TAPS - DRY/WET COIL					W24 BLOWER TAPS - DRY/WET COIL CFM				
In H2O	Blower and Vent Only	Balanced Climate	Default LO Cooling and Heating	Optional MED Cooling and Heating	Optional HI Cooling and Heating	Blower and Vent Only	Balanced Climate	Default LO Cooling and Heating	Optional MED Cooling and Heating	Optional HI Cooling and Heating
0"	680/665	520/510	680/655	865/855	Not Used	890/835	630/625	890/835	1005/980	1025/1035
.1"	615/600	435/420	615/600	810/800	Not Used	825/800	580/565	825/800	960/930	990/980
.15"	585/565	395/380	585/565	785/770	Not Used	795/780	550/535	795/780	935/910	975/955
.2"	555/535	Not Used	555/535	760/745	Not Used	770/755	525/500	770/755	910/885	955/930
.3"	495/480	Not Used	495/480	710/695	Not Used	715/705	Not Used	715/705	870/840	915/885
.4"	440/425	Not Used	440/425	665/650	Not Used	670/650	Not Used	670/650	825/805	870/845
.5"	385/375	Not Used	385/375	620/605	Not Used	630/585	Not Used	630/585	785/765	825/805

ESP	W30 BLOWER TAPS - DRY/WET COIL CFM					W36 BLOWER TAPS - DRY/WET COIL CFM				
In H2O	Blower and Vent Only	Balanced Climate	Default LO Cooling and Heating	Optional MED Cooling and Heating	Optional HI Cooling and Heating	Blower and Vent Only	Balanced Climate	Default LO Cooling and Heating	Optional MED Cooling and Heating	Optional HI Cooling and Heating
0"	1050/1020	830/825	1050/1020	1170/1135	1200/1205	1255/1225	925/900	1255/1225	1365/1345	1495/1480
.1"	1000/975	765/745	1000/975	1120/1105	1170/1155	1205/1175	850/825	1205/1175	1320/1300	1445/1425
.15"	975/950	730/705	975/950	1095/1085	1150/1130	1180/1150	815/790	1180/1150	1295/1275	1415/1395
.2"	950/925	700/670	950/925	1070/1060	1130/1105	1155/1125	780/755	1155/1125	1275/1250	1385/1360
.3"	890/870	630/605	890/870	1025/1015	1085/1055	1100/1070	700/685	1100/1070	1225/1195	1313/1280
.4"	830/815	Not Used	830/815	975/955	1040/1000	1050/1015	Not Used	1050/1015	1180/1140	1225/1185
.5"	770/755	Not Used	770/755	930/980	985/945	1000/960	Not Used	1000/960	1130/1075	1130/1075

Above data is with 1" standard throwaway filter and 1" washable filter.  
 For optional 2" pleated filter - reduce ESP by .15in.  
 See installation instructions for maximum ESP information on various KW application.

Five factory programmed speed taps (torque settings) are available for the indoor blower motor, and are selected through different unit modes of operation. These modes are energized by 24VAC signals from the low voltage terminal block located inside the control panel by a thermostat or other controlling device.

1. Blower and Ventilation Only Speed is the CFM amount for continuous fan and ventilation without a call for cooling.
2. Balanced Climate Speed is the indoor CFM amount for user selectable Balanced Climate operation and optional Mechanical Dehumidification. To use Balanced Climate, remove the jumper between Y1 and Y2 on the low voltage terminal strip. A 2 stage cooling thermostat is then used to control blower airflow stages. Be sure to follow all guidelines provided in the installation manual. A controls kit that includes a low ambient control (LAC) must be used for Balanced Climate Operation if ventilation options are to be used or cooling operation will occur below a 60° outdoor temperature. Balanced Climate can be used for duct free and ducted applications below 0.20"WC ESP total static. Balanced Climate provides increased moisture removal during the cooling cycle, but is not a replacement for optional mechanical dehumidification. Optional mechanical dehumidification provides moisture removal without significantly cooling the space being conditioned. Mechanical dehumidification is highly recommended for applications requiring indoor humidity control for schools, public areas, agricultural, pharmaceutical, and areas with high outdoor humidity and varying indoor heat load.
3. Default LO Cooling and Heating Speed is the indoor CFM amount for cooling operation using the default blower speed tap selection. This speed is labeled as LO on the speed selection terminal strip inside the unit control panel. All units ship with cooling and heating operation at LO cooling and heating speed, and provides the optimal airflow amount for normal use.
4. Optional MED Cooling and Heating Speed is selected manually during unit setup and provides a higher indoor CFM for hi static duct applications and increased airflow. This speed is labeled as MED on the speed selection terminal strip inside the unit control panel.
5. Optional HI Cooling and Heating Speed is selected manually during unit setup and provides the highest allowable indoor CFM amount. Not recommended for standard unit operation. This speed is labeled as HI on the speed selection terminal strip inside the unit control panel.

////// SOUND DATA - DBA @ 5 FT. AND 10 FT.\*

DUCT FREE	INDOOR COOLING OPERATION @ 5 FT.			INDOOR COOLING OPERATION @ 10 FT.			OUTDOOR @ 10 FT.
Unit	StandardGrilles	With WMICF	With WMICF and WAPR-11	Standard Grilles	With WMICF	With WMICF and WAPR-11	Standard Features
W18AB/W18LB	49.6	47.3	45.1	47.3	45.2	42.9	62.8
W24AB/W24LB	52.4	49.7	46.9	50.4	46.9	44.8	62.3
W30AB/W30LB	53.9	52.8	50.3	52.9	50.4	48.8	67.1
W36AB/W36LB	53.9	52.8	50.3	52.9	50.4	48.8	67.1

DUCTED SUPPLY	INDOOR COOLING OPERATION @ 5 FT.			INDOOR COOLING OPERATION @ 10 FT.			OUTDOOR @ 10 FT.
Unit	StandardGrilles	With WMICF	With WMICF and WAPR-11	Standard Grilles	With WMICF	With WMICF and WAPR-11	Standard Features
W18AB/W18LB	48.6	45.5	44.9	46.2	44.0	43.1	62.8
W24AB/W24LB	51.9	47.4	44	48.9	42.9	41.4	62.3
W30AB/W30LB	54.5	47.3	45.6	47.3	44.7	43.2	67.1
W36AB/W36LB	54.5	47.3	51.1	47.3	44.7	48.5	67.1

Integrated values calculated per ANSI/ASA S12.60-2009/Part 2, Section 5.2.2.1, Integrated Sound Values are also applicable for use in learning spaces for LEED schools; EQ Prerequisite 3 - Minimum Acoustical Performance, OPTION 1. Using methods prescribed in ANSI S12.60, classroom must achieve a maximum background noise level of 45dBA. Results referenced were recorded in the Bard Manufacturing Company, Inc. Sound Lab Facility. Actual Field Application results may vary with classroom design and construction methods.

///// ELECTRICAL SPECIFICATIONS — W\*\*AB SERIES

MODEL	Rated Volts & Phase	No. Field Power Circuits	Single Circuit				Multiple Circuit												
			③ Minimum Circuit Ampacity	① Maximum External Fuse or Ckt. Brkr.	② Field Power Wire Size	② Ground Wire	③ Minimum Circuit Ampacity		① Maximum External Fuse or Ckt. Breaker		② Field Power Wire Size		② Ground Wire Size						
							Ckt. A	Ckt. B	Ckt. A	Ckt. B	Ckt. A	Ckt. B	Ckt. A	Ckt. B					
W18AB-A00, A02 A05 A08 A10	230/208-1	1	16	20	12	12													
		1	30	30	10	10													
		1	45	45	8	10													
		1	56	60	6	10													
W24AB-A00, A02 A05 A08 A10	230/208-1	1	21	30	10	10													
		1	30	30	8	10													
		1	46	50	8	10													
		1	57	60	6	10													
W24AB-B00, B02 B06	230/208-3	1	15	20	12	14													
		1	23	25	10	10													
W24AB-C00, C02 C06	460-3	1	8	10	14	14													
		1	12	15	14	14													
W30AB-A00, A02 A05 A08 A10 A15	230/208-1	1	23	35	8	10													
		1	31	35	8	10													
		1	46	50	8	10													
		1	57	60	6	10													
		1 or 2	83	90	4	8	57	26	60	30	6	10	10	10					
W30AB-B00, B02 B06 B09 B15	230/208-3	1	17	20	12	12													
		1	23	25	10	10													
		1	32	35	8	10													
		1	50	50	8	10													
W30AB-C00, C02 C06 C09 C12 C15	460-3	1	9	10	14	14													
		1	12	15	14	14													
		1	16	20	12	12													
		1	20	20	12	12													
		1	25	25	10	10													
W36AB-A00, A02 A05 A08 A10 A15	230/208-1	1	27	40	8	10													
		1	32	40	8	10													
		1	48	50	8	10													
		1	58	60	6	10													
		1 or 2	84	90	4	8	58	26	60	30	6	10	10	10					
W36AB-B00, B02 B06 B09 B15	230/208-3	1	20	25	10	10													
		1	24	25	10	10													
		1	33	35	8	10													
		1	51	60	6	10													
W36AB-C00, C02 C06 C09 C15	460-3	1	9	10	14	14													
		1	11	15	14	14													
		1	15	15	14	14													
		1	24	25	10	10													

///// ELECTRICAL SPECIFICATIONS — W\*\*ABD SERIES DEHUM SERIES

W30ABDA00, A02 A05 A08 A10	230/208-1	1	23	35	8	10													
		1	31	35	8	10													
		1	46	50	8	10													
		1	57	60	6	10													
W30ABDB00, B02 B06 B09	230/208-3	1	17	20	12	12													
		1	23	25	10	10													
		1	32	35	8	10													
W30ABDC00, C02 C06 C09	460-3	1	10	15	14	14													
		1	13	15	14	14													
		1	17	20	12	12													
W36ABDA00, A02 A05 A08 A10	230/208-1	1	28	40	8	10													
		1	32	40	8	10													
		1	48	50	8	10													
		1	58	60	6	10													
W36ABDB00, B02 B06 B09	230/208-1	1	20	25	10	10													
		1	24	25	10	10													
		1	33	35	8	10													
W36ABDC00, C02 C06 C09	460-3	1	13	15	14	14													
		1	14	15	14	14													
		1	18	20	12	12													

- ① Maximum size of the time delay fuse or circuit breaker for protection of field wiring conductors.
- ② Based on 75°C copper wire. All wiring must conform to the National Electrical Code and all local codes.
- ③ These "Minimum Circuit Ampacity" values are to be used for sizing the field power conductors. Refer to the National Electrical code (latest version), Article 310 for power conductor sizing.

**CAUTION:** When more than one field power circuit is run through one conduit, the conductors must be derated. Pay special attention to Note 8 of Table 310 regarding Ampacity Adjustment Factors when more than three current carrying conductors are in a raceway.

**IMPORTANT:** While this electrical data is presented as a guide, it is important to electrically connect properly sized fuses and conductor wires in accordance with the National Electrical Code and all local codes.

////// ELECTRICAL SPECIFICATIONS — W\*\*LB SERIES

MODEL	Rated Volts & Phase	No. Field Power Circuits	Single Circuit				Dual Circuit												
			③ Minimum Circuit Ampacity	① Maximum External Fuse or Ckt. Brkr.	② Field Power Wire Size	② Ground Wire	③ Minimum Circuit Ampacity		① Maximum External Fuse or Ckt. Breaker		② Field Power Wire Size		② Ground Wire Size						
							Ckt. A	Ckt. B	Ckt. A	Ckt. B	Ckt. A	Ckt. B	Ckt. A	Ckt. B					
W18LB-A00, A0Z A05 A08 A10	230/208-1	1	16	20	12	12													
		1	30	30	10	10													
		1	46	45	8	10													
		1	56	60	6	10													
W24LB-A00, A0Z A05 A08 A10	230/208-1	1	21	30	10	10													
		1	30	30	8	10													
		1	46	50	8	10													
		1	56	60	6	10													
W24LB-B00, B0Z B06	230/208-3	1	15	20	12	14													
		1	23	25	10	10													
W30LB-A00, A0Z A05 A08 A10 A15	230/208-1	1	26	35	8	10													
		1	31	35	8	10													
		1	46	50	8	10													
		1	57	60	6	10													
		1 or 2	83	90	4	8	57	26	60	30	6	10	10	10					
W30LB-B00, B0Z B09 B15	230/208-3	1	19	20	12	12													
		1	32	35	8	10													
		1	50	60	6	10													
W30LB-C00, C0Z C09 C15	460-3	1	9	10	14	14													
		1	16	20	12	12													
		1	25	25	10	10													
W36LB-A00, A0Z A05 A10 A15	230/208-1	1	27	40	8	10													
		1	32	40	8	10													
		1	58	60	6	10													
		1 or 2	84	90	4	8	58	26	60	30	6	10	10	10					
W36LB-B00, B0Z B09 B15	230/208-3	1	20	25	10	10													
		1	33	35	8	10													
		1	51	60	6	10													
W36LB-C00, C0Z C09 C15	460-3	1	9	10	14	14													
		1	15	15	14	14													
		1	24	25	10	10													

- ① Maximum size of the time delay fuse or circuit breaker for protection of field wiring conductors.
- ② Based on 75°C copper wire. All wiring must conform to the National Electrical Code and all local codes.
- ③ These "Minimum Circuit Ampacity" values are to be used for sizing the field power conductors. Refer to the National Electrical code (latest version), Article 310 for power conductor sizing.

**CAUTION:** When more than one field power circuit is run through one conduit, the conductors must be derated. Pay special attention to Note 8 of Table 310 regarding Ampacity Adjustment Factors when more than three current carrying conductors are in a raceway.

**IMPORTANT:** While this electrical data is presented as a guide, it is important to electrically connect properly sized fuses and conductor wires in accordance with the National Electrical Code and all local codes.

## HEATER PACKAGES - FIELD INSTALLED "A" SERIES RIGHT-HAND UNITS

- Designed for adding Electric Heat to 0 KW Units
- ETL US & Canada Listed
- Circuit Breaker Standard on 230/208V Models
- Toggle Disconnect Standard on 460V Models

Air Conditioner Models	-A00 Models 230/208-1		-B00 Models 230/208-3		-C00 Models 460-3	
	Heater Model #	KW	Heater Model #	KW	Heater Model #	KW
W18AB	WMCB-02A EHW1TAB-A05 EHW1TAB-A08 EHW2TA-A10	02 5 8 10	N/A		N/A	
W24AB	WMCB-03A EHW2TAB-A05 EHW2TAB-A08 EHW2TA-A10	02 5 8 10	WMCB-01B EHW2TA-B06	02 6	WMPD-01C EHW24B-C06	02 6
W30AB	WMCB-05A EHW3TA-A05 EHW3TA-A08 EHW3TA-A10 EHW3TAB-A15	02 5 8 10 15	WMCB-02B EHW30A-B06 EHW3TA-B09 EHW3TAB-B15	02 6 9 15	WMPD-01C EHW3TA-C06 EHW3TA-C09 EHW3TA-C12 EHW3TAB-C15	02 6 9 12 15
W36AB	WMCB-05A EHW3TA-A05 EHW3TA-A08 EHW3TAB-A10 EHW3TA-A15	02 5 8 10 15	WMCB-03B EHW3TA-B06 EHW3TAB-B09 EHW3TA-B15	02 6 9 15	WMPD-01C EHW3TA-C06 EHW3TA-C09 EHW3TA-C15	02 6 9 15

## HEATER PACKAGES - FIELD INSTALLED "L" SERIES LEFT-HAND UNITS

Air Conditioner Models	-A00 Models 230/208-1		-B00 Models 230/208-3		-C00 Models 460-3	
	Heater Model #	KW	Heater Model #	KW	Heater Model #	KW
W18LB	WMCB-02AL EHW1TAB-A05L EHW1TAB-A08L EHW2TA-A10L	02 05 08 10	N/A		N/A	
W24LB	WMCB-03AL EHW2TAB-A05L EHW2TAB-A08L EHW2TA-A10L	02 05 08 10	WMCB-01BL EHW2TA-B06L	02 06	N/A	
W30LB	WMCB-05AL EHW3TA-A05L EHW3TA-A08L EHW3TA-A10L EHW3TA-A15L	02 05 08 10 15	WMCB-02BL EHW3TA-B09L EHW3TAB-B15L	02 09 15	WMPD-01CL EHW3TA-C09L EHW3TAB-C15L	02 09 15
W36LB	WMCB-05AL EHW3TA-A05L EHW3TAB-A10L EHW3TA-A15L	02 05 10 15	WMCB-03BL EHW3TAB-B09L EHW3TA-B15L	02 09 15	WMPD-01CL EHW3TA-C09L EHW3TA-C15L	02 09 15

## ////// ELECTRIC HEAT TABLE - REFER TO ELECTRICAL SPECIFICATIONS FOR AVAILABILITY BY UNIT MODEL

NOMINAL KW	AT 240V (1)				AT 208V (1)				AT 480V (2)			AT 460V (2)		
	KW	1-PH AMPS	3-PH AMPS	BTUH	KW	1-PH AMPS	3-PH AMPS	BTUH	KW	3-PH AMPS	BTUH	KW	3-PH AMPS	BTUH
4.0	4.0	16.7		13,652	3.00	14.4		10,239						
5.0	5.0	20.8		17,065	3.75	18.0		12,799						
6.0	6.0		14.4	20,478	4.50		12.5	15,359	6.0	7.2	20,478	5.52	6.9	18,840
8.0	8.0	33.3		27,304	6.00	28.8		20,478						
9.0	9.0		21.7	30,717	6.75		18.7	23,038	9.0	10.8	30,717	8.28	10.4	28,260
10.0	10.0	41.7		34,130	7.50	36.1		25,598						
15.0	15.0	62.5	36.1	51,195	11.25	54.1	31.2	38,396	15.0	18.0	51,195	13.80	17.3	47,099
18.0	18.0		43.3	61,434	13.50		37.5	46,076	18.0	21.7	61,434	16.56	20.8	56,519
20.0	20.0	83.3		68,260	15.00	72.1		51,195						

(1) These electric heaters are available in 230/208V units only.

(2) These electric heaters are available in 480V units only.

## ////// WALL MOUNT™ VENTILATION OPTION SELECTION CHART

VENT CODE	FIELD INSTALL KIT	UNIT	OPERATION	DESCRIPTION
X	FAD-NE2	W18AB/LB, W24AB/LB	Barometric	Air damper provides slight positive room pressure during blower operation, No room air exhaust.
	FAD-NE3	W30AB/LB, W36AB/LB	Barometric	
A	FAD-BE2	W18AB/LB, W24AB/LB	Barometric	Air damper provides slight positive room pressure during blower operation, barometric room air exhaust.
	FAD-BE3	W30AB/LB, W36AB/LB	Barometric	
B	BOP2	W18AB/LB, W24AB/LB	No Ventilation	Insulated plates used to seal vent intake and exhaust openings.
	BOP3	W30AB/LB, W36AB/LB	No Ventilation	
M	CRV-F2-*	W18AB/LB, W24AB/LB	24V On/Off	Vent Provides motorized spring return on/off operation to bring in outdoor air and exhaust room air. No intake hood required. Replaces the motorized fresh air damper.
	CRV-F3-*	W30AB/LB, W36AB/LB	24V On/ff	
V	CRV-V2-*	W18AB/LB, W24AB/LB	24V On/Off, 0-10V	Vent provides motorized spring return 0-10V variable or on/off operation to bring in outdoor air and exhaust room air. Minimum and occupied vent blade positions. No intake hood required.
	CRV-V3-*	W30AB/LB, W36AB/LB	24V On/Off, 0-10V	
D	ECON-NC2-*	W18AB/LB, W24AB/LB	2-10V only	Full flow Economizer that uses 2-10V signal from a DDC control system or thermostat. 7" intake hood required.
	ECON-NC3-*	W30AB/LB, W36AB/LB	2-10V only	
S	ECON-S2-*	W18AB/LB, W24AB/LB	JADE Controller	Partial flow Economizer that uses the JADE controller and included sensors to operate free cooling. Enthalpy operation user adjustable. No intake hood required.
	ECON-S3-*	W30AB/LB, W36AB/LB	JADE Controller	
Y	ECON-DB2-*	W18AB/LB, W24AB/LB	JADE Controller	Full flow Economizer that uses the JADE controller and included sensors to operate free cooling. Dry Bulb operation user adjustable. 7" intake hood required.
	ECON-DB3-*	W30AB/LB, W36AB/LB	JADE Controller	
Z	ECON-WD2-*	W18AB/LB, W24AB/LB	JADE Controller	Full flow Economizer that uses the JADE controller and included sensors to operate free cooling. Enthalpy operation user adjustable. 7" intake hood required.
	ECON-WD3-*	W30AB/LB, W36AB/LB	JADE Controller	
R	ERV-FA2-*	W18AB/LB, W24AB/LB	24V On/Off, 3 blower speeds	208/230V Energy Recovery ventilator with energy wheel media. 3 independently selected intake and exhaust blower speeds. 3" intake hood required.
	ERV-FA3-*	W30AB/LB, W36AB/LB	24V On/Off, 3 blower speeds	
	ERV-FC2-*	W18AB/LB, W24AB/LB	24V On/Off, 3 blower speeds	460V Energy recovery ventilator with energy wheel media. 3 independently selected intake and exhaust blower speeds. 3" intake hood required.
	ERV-FC3-*	W30AB/LB, W36AB/LB	24V On/Off, 3 blower speeds	

\* = Insert color to match unit (X= Beige, 1= White, 4= Buckeye Gray, 5= Desert Brown, 8= Dark Bronze)

**“X” Vent Code Option – Standard Fresh Air Damper No Exhaust (FAD-NE)**

The barometric fresh air damper without exhaust is a standard feature on all models. It is installed on the inside of the service door and allows outside ventilation air, up to 25% of the total airflow rating of the unit, to be introduced through the air inlet openings and to be mixed with the conditioned air. The damper opens during blower operation and closes when the blower is off. Adjustable blade stops allow different amounts of outside air to be introduced into the building and can be easily locked closed if required. The room exhaust air path is sealed with an insulated block-off plate.

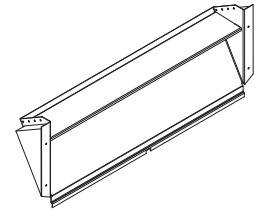

Barometric Fresh Air Damper MIS-3754

**“A” Vent Code Option – Fresh Air Damper with Barometric Exhaust (FAD-BE)**

The barometric fresh air damper with exhaust is an optional feature on all models. It is installed on the inside of the service door and allows outside ventilation air, up to 25% of the total airflow rating of the unit, to be introduced through the air inlet openings and to be mixed with the conditioned air. The damper opens during blower operation and closes when the blower is off. Adjustable blade stops allow different amounts of outside air to be introduced into the building and can be easily locked closed if required. The room exhaust air path uses a barometric damper design that relieves room pressurization during outdoor air intake. Adjustable blade stops allow room pressure adjustment by controlling the amount of exhaust air leaving the building.

**“B” Vent Code Option – Blank Off Plate (BOP)**

Blank off plates are installed on the inside of the service door and over the exhaust opening in the condenser partition. The plate covers the air inlet, which restricts any outside air from entering the unit. The blank off plate option may be utilized in applications where outside air intake is not required by state or local codes.

**“M” Vent Code Option – Commercial Room Ventilator with fixed blade position (CRV-F)**

The built-in commercial room ventilator with fixed blade position is internally mounted behind the service door and allows outside ventilation air, up to 50% of the total airflow rating of the unit. It includes a built-in exhaust air damper for room pressurization relief. Blade stops are easily adjustable to set intake airflow. The commercial room ventilator with fixed blade position (CRV-F) is a simple and innovative approach to improving the indoor air quality by providing fresh air intake and exhaust capability. The CRV-F can be activated by indoor blower operation or independently controlled by a thermostat or controller using a 24VAC occupancy or schedule signal. Blade operation is controlled by a on/off spring return motor that closes rapidly when de-energized. Blade seals provide minimal blade leakage.

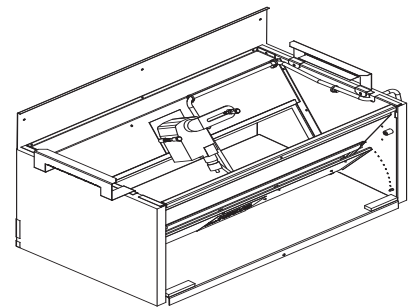

MIS-4009

Commercial Room Ventilator-Fixed

**“V” Vent Code Option – Commercial Room Ventilator with Modulating Blade position (CRV-V)**

The built-in commercial room ventilator with modulating blade position is internally mounted behind the service door and allows outside ventilation air, up to 50% of the total airflow rating of the unit. It includes a built-in exhaust air damper for room pressurization relief. Blade seals allow for minimal blade leakage. A ventilation control board allows multiple blade settings to adjust intake airflow. By setting multiple blade positions, pre-purge, occupied, and unoccupied airflow amounts are possible with capable thermostats and controllers. The CRV-V also allows for 0-10V input for modulating ventilation control based on CO2 levels. Complies with ANSI/ASHRAE Standard 62.1 “Ventilation for Acceptable Indoor Air Quality” and other state and local ventilation codes that require outdoor air intake but not economizer operation.

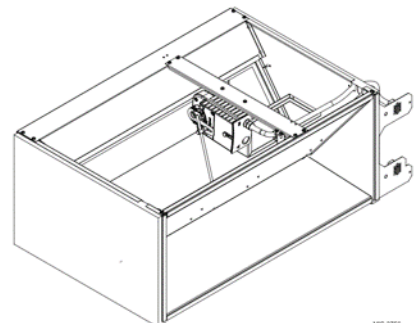

MIS-3756

Commercial Room Ventilator- Modulating

**“D” Vent Code Option – Economizer without controls installed (ECON-NC)**

The built-in economizer is internally mounted behind the service door and allows outside ventilation air, up to 100% of the total airflow rating of the unit. It includes a built-in exhaust air damper for room pressurization relief. The economizer is designed to provide “free cooling” when outside air conditions are cool and dry enough to satisfy cooling requirements without running the compressor. This provides lower operating costs, extended equipment life, and cooling operation at cold (-40°F) outdoor temperatures. The ECON-NC does not contain unit ventilation controls, and provides a 2-10V Belimo actuator motor with spring return. Blade seals are used to minimize blade leakage. Controls are provided by using a field supplied DDC system, or a thermostat capable of 2-10V economizer operation. Indoor and outdoor temperature sensors are not provided with the ventilation option, and must be ordered separately.

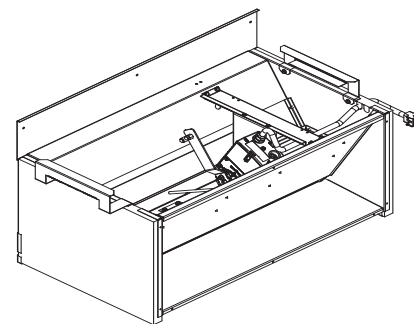

MS-4010  
Economizer, No Controls

**“S, Y and Z” Vent Code Option – Economizers with JADE® Controller (ECON-S, ECON-DB, ECON-WD)**

The JADE controlled economizer is internally mounted behind the service door and allows outside ventilation air. The ECON-S allows up to 50% of the total airflow of the unit. The ECON-WD and ECON-WB allows up to 100% of the total airflow rating of the unit. Both include a built-in exhaust air damper for room pressurization relief. The economizer is designed to provide “free cooling” when outside air conditions are cool and dry enough to satisfy cooling requirements without running the compressor. This provides lower operating costs, extended equipment life, and cooling operation down to -40°F outdoor temperatures. The “S” economizer does not require an intake hood. The “Y” and “Z” economizer requires a 7” air intake hood.

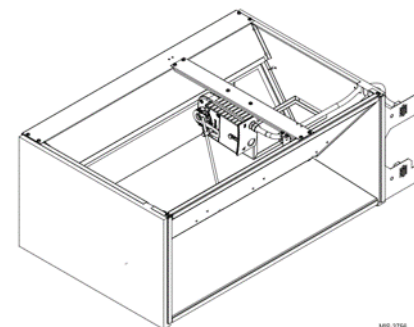

MS-3750  
Economizer, Jade Control

**“S, Y and Z” Vent Code Option – (ECON-S, ECON-DB, ECON-WD) JADE® Controller Information**

JADE Economizer controls provide Demand Ventilation Control, operational checkout, an easy to read LCD screen, configurable freeze protection, and LCD displayed economizer component failure alarms. Minimum vent position, occupancy ventilation, and 0-10V CO2 input is available for use with select CO2 room sensors. Economizer operation can be controlled by outdoor dry bulb (ECON-DB) or outdoor enthalpy (ECON-S, ECON-WB) measurement. When used with a Bard economizer assembly, the JADE controller is able to meet many state and local codes for economizer use.



Jade Control Module

**JADE Controller Specifications:**

- Operating Humidity Range (% RH) 5 to 95% RH, non-condensing
- Contact Ratings 30 VAC-- 1.5 A Run, 3.5 A Inrush
- Voltage 20 to 30 VAC RMS
- Operating Temperature Range (F) -40 F to +150 F
- Operating Temperature Range (C) -40 C to +65 C
- Approvals, Federal Communications Commission Compliant
- Approvals, CE Compliant
- Complies with California Title 24
- Mixed air and Outdoor Sensor using Syk Bus.
- Output 0-10 VDC to actuator, Syk Bus.

**“R” Vent Code Option – Energy Recovery Ventilator (ERV-F)**

The wall-mount energy recovery ventilator (ERV) is a highly innovative approach to meeting indoor air quality ventilation requirements as established by ANSI/ASHRAE Standard 62.1. The ERV allows up to 400 CFM (depending upon model) of fresh air and exhaust through the unit while maintaining superior indoor comfort and humidity levels. In most cases this can be accomplished without increasing equipment sizing or operating costs. Heat transfer efficiency is up to 67% during summer and 75% during winter conditions.

The ERV consists of a unique “rotary energy recovery cassette” that provides effective sensible and latent heat transfer capabilities during summer and winter conditions. Various control schemes are addressed including limiting ventilation during building occupancy only. The ERV is designed to be internally mounted behind the service door, and includes independent blowers for intake air and exhaust air balancing. It can be built-in at the factory (W\*\*A only) or field installed (W\*\*A and W\*\*L) as an option. Wiring includes plug-in harnesses for easy vent installation and removal. A 3” intake hood with pre-filter is required for ERV installations.

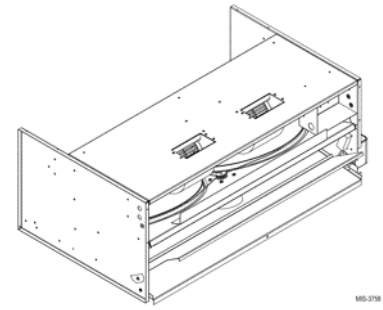

Energy Recovery Ventilator

*Typical load reductions for ERV-F3*

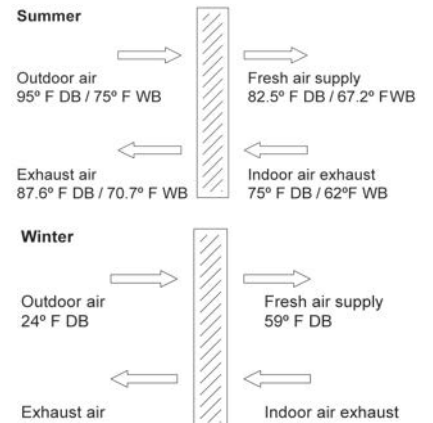

# WALL MOUNT™ BAROMETRIC DAMPER (FAD) PERFORMANCE

## “X” (FAD-NE2 and FAD-NE3) Barometric Damper Without Exhaust Vent Code Options

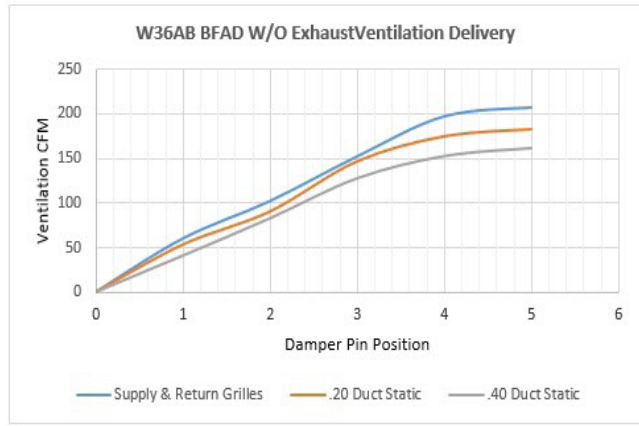
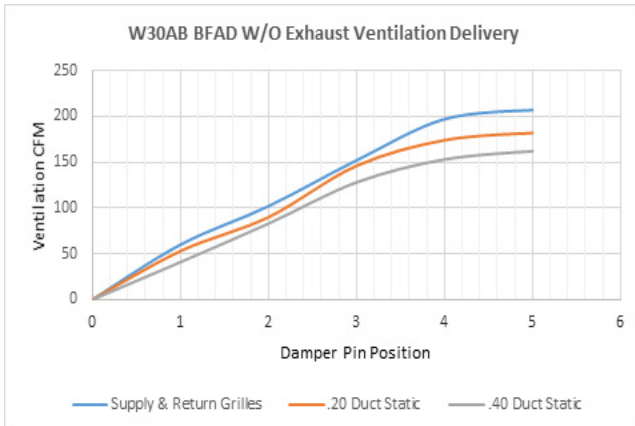
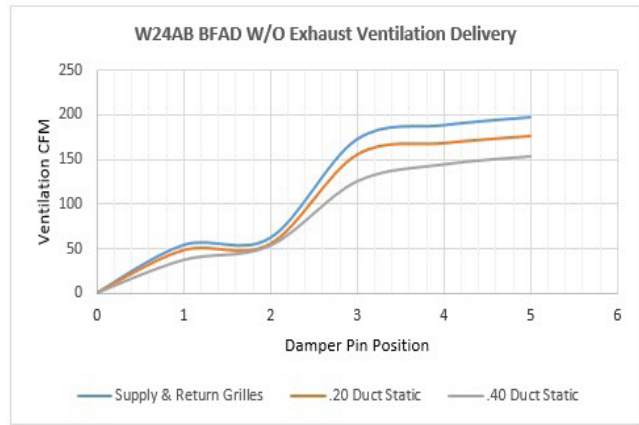
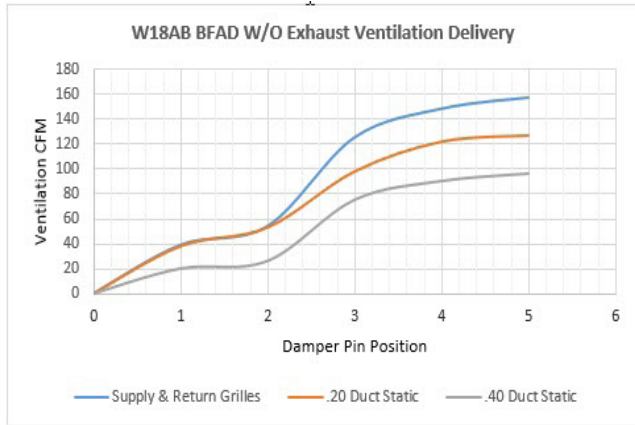

## “A” (FAD-BE2 and FAD-BE3) Barometric Damper With Exhaust Vent Code Options

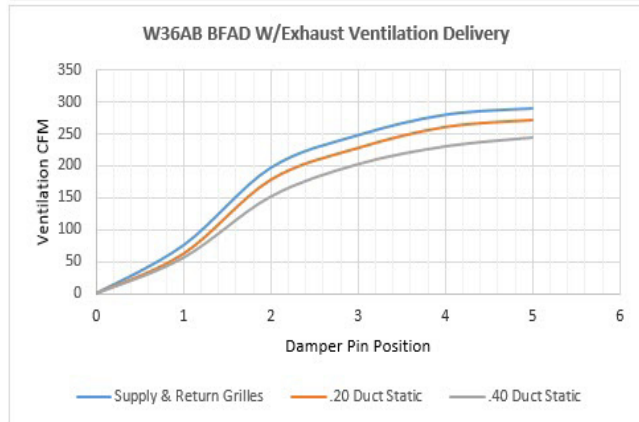
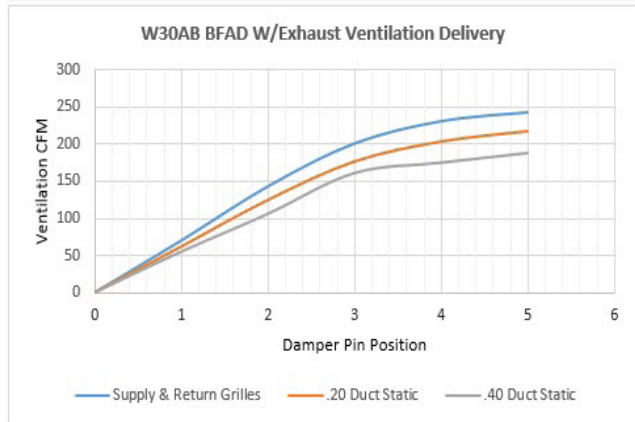
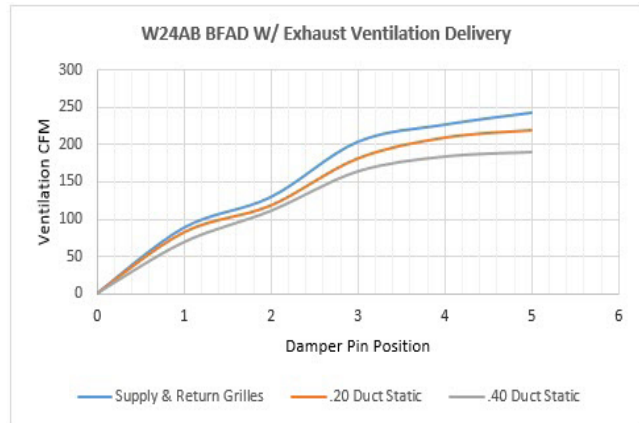
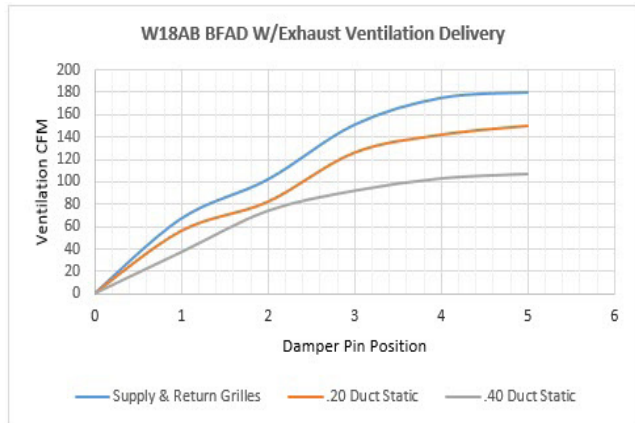

////// WALL MOUNT™ VENTILATION AIRFLOW CHARTS

“M” (CRV-F), “V” (CRV-V), “S” (ECON-S) Vent Code Options

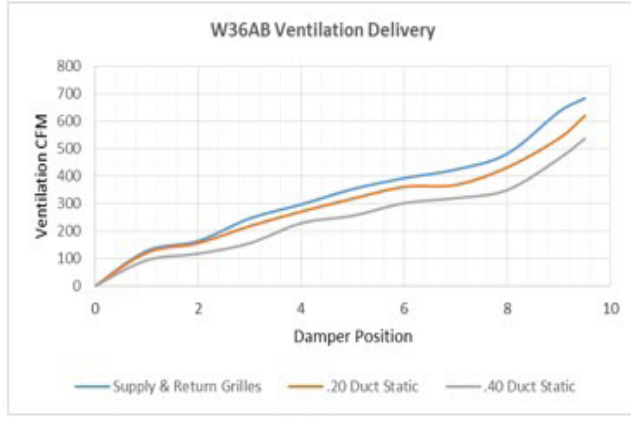
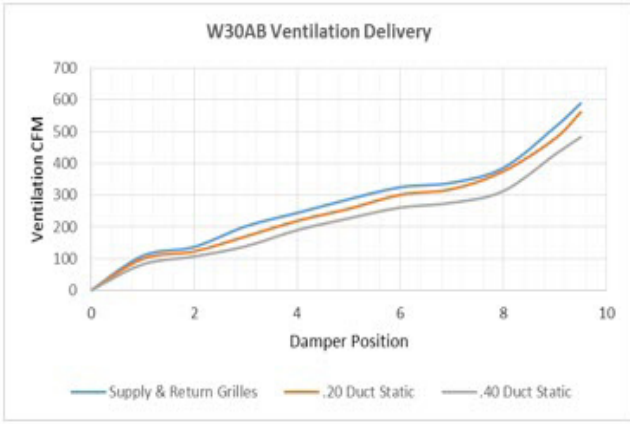
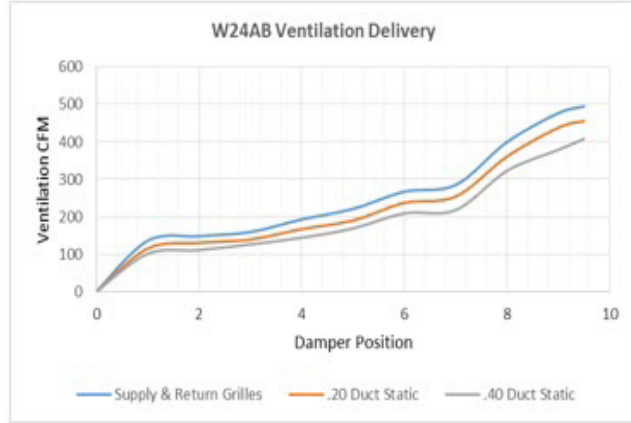
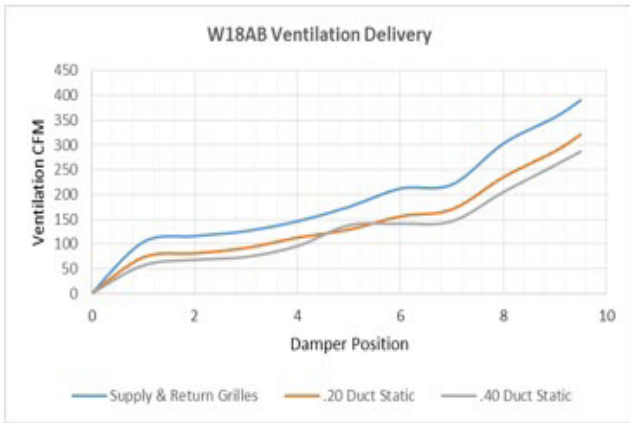

“D” (ECON-NC), “Y” (ECON-DB) and “Z” (ECON-WD) Vent Code Options

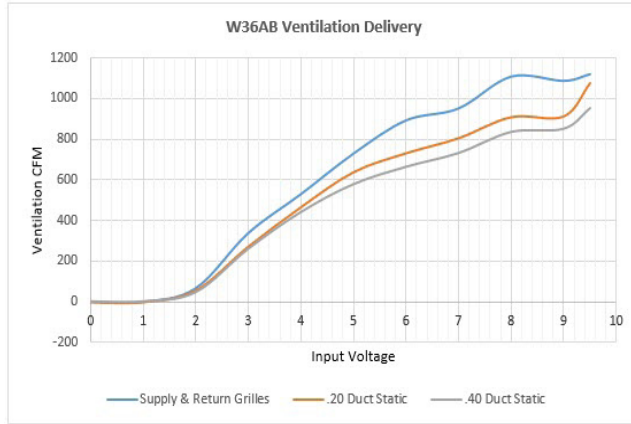
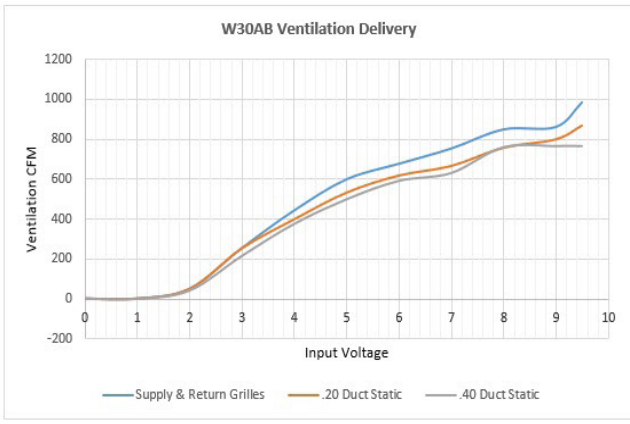
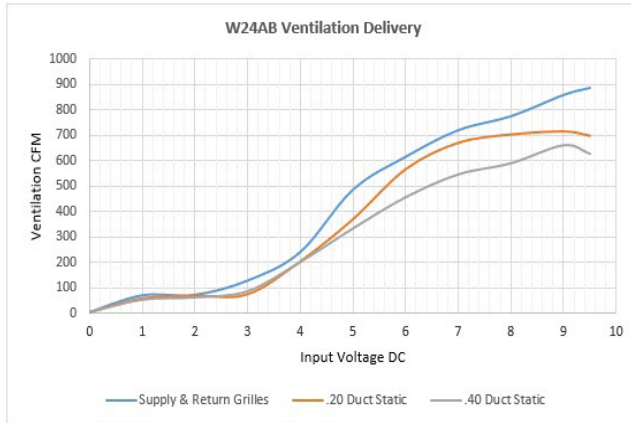
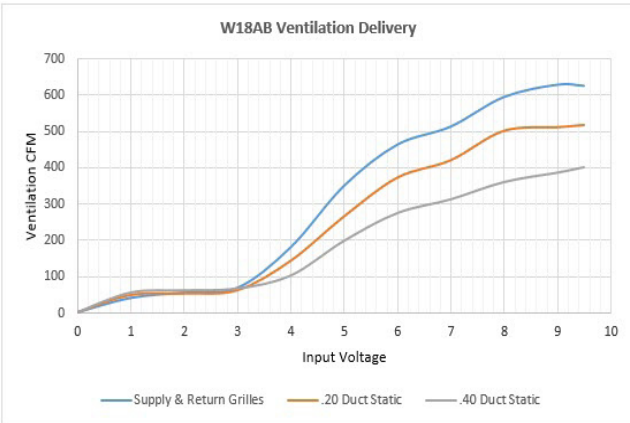

# WALL MOUNT™ ENERGY RECOVERY VENTILATION (ERV) PERFORMANCE

"R" (ERV-FA2 and ERV-FC2) Vent Code Options for W18 & W24  
 SUMMER COOLING PERFORMANCE (INDOOR DESIGN CONDITIONS 75°DB/62°WB)

AMBIENT O.D.		VENTILATION RATE -- 250 CFM 62% EFFICIENCY						VENTILATION RATE -- 225 CFM 63% EFFICIENCY						VENTILATION RATE -- 200 CFM 63% EFFICIENCY					
DB/WB	F	VLT	VLS	VLL	HRT	HRS	HRL	VLT	VLS	VLL	HRT	HRS	HRS	VLT	VLS	VLL	HRT	HRS	HRS
105	75	11925	8100	1325	7394	5022	822	10727	7287	3441	6758	4591	2168	9540	6480	3060	6010	4082	1928
	70	8100	8100	0	5022	5022	0	7287	7287	0	4591	4591	0	6480	6480	0	4082	4082	0
	65	8100	8100	0	5022	5022	0	7287	7287	0	4591	4591	0	6480	6480	0	4082	4082	0
100	80	17550	6750	10800	10881	4185	6696	15788	6072	9716	9946	3826	6121	14040	5400	8640	8845	3402	5443
	75	11925	6750	5175	7394	4185	3209	10727	6072	4655	6758	3826	2933	9540	5400	4140	6010	3402	2608
	70	6863	6750	113	4255	4185	70	6173	6072	101	3889	3826	64	5490	5400	90	3458	3402	56
	65	6750	6750	0	4185	4185	0	6072	6072	0	3826	3826	0	5400	5400	0	3402	3402	0
95	80	17550	5400	12150	10881	3348	7533	15788	4858	10930	9946	3060	6886	14040	4320	9720	8845	2722	6124
	75	11925	5400	6525	7394	3348	4046	10727	4858	5870	6758	3060	3698	9540	4320	5220	6010	2722	3289
	70	6863	5400	1463	4255	3348	907	6173	4858	1315	3889	3060	829	5490	4320	1170	3458	2722	737
	65	5400	5400	0	3348	3348	0	4858	4858	0	3060	3060	0	4320	4320	0	2722	2722	0
90	80	17550	4050	13500	10881	2511	8370	15788	3643	12145	9946	2295	7651	14040	3240	10800	8845	2041	6804
	75	11925	4050	7875	7394	2511	4883	10727	3643	7084	6758	2295	4463	9540	3240	6300	6010	2041	3969
	70	6863	4050	2813	4255	2511	1744	6173	3643	2530	3889	2295	1594	5490	3240	2250	3458	2041	1417
	65	4050	4050	0	2511	2511	0	3643	3643	0	2295	2295	0	3240	3240	0	2041	2041	0
85	80	17550	2700	14850	10881	1674	9207	15788	2429	13359	9946	1530	8416	14040	2160	11880	8845	1361	7484
	75	11925	2700	9225	7394	1674	5720	10727	2429	8298	6758	1530	5228	9540	2160	7380	6010	1361	4649
	70	6863	2700	4163	4255	1674	2581	6173	2429	3744	3889	1530	2359	5490	2160	3300	3458	1361	2098
	65	2700	2700	0	1674	1674	0	2429	2429	0	1530	1530	0	2160	2160	0	1361	1361	0
80	75	11925	1350	10575	7394	837	6557	10727	1214	9513	6758	765	5993	9540	1080	8460	6010	680	5330
	70	6863	1350	5513	4255	837	3418	6173	1214	4959	3889	765	3124	5490	1080	4410	3458	680	2778
	65	2363	1350	1013	1465	837	628	2125	1214	911	1339	765	547	1890	1080	810	1190	680	510
	60	1350	1350	0	837	837	0	1214	1214	0	765	765	0	1080	1080	0	680	680	0
75	70	6863	0	6863	4255	0	4255	6173	0	6173	6889	0	3889	5490	0	5490	3458	0	3458
	65	2363	0	2363	1465	0	1465	2125	0	2125	1339	0	1339	1890	0	1890	1190	0	1190
	60	0	0	0	0	0	0	0	0	0	0	0	0	0	0	0	0	0	0

WERVP-A2 WINTER HEATING PERFORMANCE (INDOOR DESIGN CONDITIONS 70°F DB)

AMBIENT O.D.	VENTILATION RATE					
	250 CFM 74% EFF.		225 CFM 75% EFF.		200 CFM 75% EFF.	
DB/°F	WVL	WVL	WVL	WVL	WVL	WHR
65	1350	999	1214	911	1080	810
60	2700	1998	2429	1822	2160	1620
55	4050	2997	3643	2733	3240	2430
50	5400	3996	4858	3643	4320	3240
45	6750	4995	6072	4554	5400	4050
40	8100	5994	7287	5465	6480	4860
35	9450	6993	8501	6376	7560	5670
30	10800	7992	9716	7287	8640	6480
25	12150	8991	10930	8198	9720	7290
20	13500	9990	12145	9108	10800	8100
15	14850	10989	13359	10019	11880	8910

NOTE: Sensible performance only is shown for winter application.

LEGEND:

- VLT = Ventilation Load - Total
- VLS = Ventilation Load - Sensible
- VLL = Ventilation Load - Latent
- HRT = Heat Recovery - Total
- HRS = Heat Recovery - Sensible
- HRL = Heat Recovery - Latent
- WVL = Winter Ventilation Load
- WHR = Winter Heat Recovery

# WALL MOUNT™ ENERGY RECOVERY VENTILATION (ERV) PERFORMANCE

“R” (ERV-FA3 and ERV-FC3) Vent Code Options for W30 & W36  
 SUMMER COOLING PERFORMANCE (INDOOR DESIGN CONDITIONS 75°DB/62°WB)

AMBIENT O.D.	VENTILATION RATE -- 400CFM 63% EFFICIENCY						VENTILATION RATE -- 325 CFM 64% EFFICIENCY						VENTILATION RATE -- 250 CFM 65% EFFICIENCY						
	DB/ WB	F	VLT	VLS	VLL	HRT	HRS	HRL	HRS	HRS	HRS	HRS	HRS	HRL	HRS	HRS	HRS	HRS	HRS
105	75	19080	12960	6120	12020	8164	3855	15502	10530	4972	9921	6739	3182	11925	8100	3825	7751	5265	2486
	70	12960	12960	0	8164	8164	0	10530	10530	0	6739	6739	0	8100	8100	0	5265	5265	0
	65	12960	12960	0	8164	8164	0	10530	10530	0	6739	6739	0	8100	8100	0	5265	5265	0
100	80	28080	10800	17280	17690	6804	10886	22815	8775	14040	14601	5616	8985	17550	6750	10800	11407	4387	7019
	75	19080	10800	8280	12020	6804	5216	15502	8775	6727	9921	5616	4305	11925	6750	5175	7751	4387	3363
	70	10980	10800	180	6717	6804	113	8921	8775	146	5709	5616	93	6862	6750	112	4460	4387	73
	65	10800	10800	0	6804	6804	0	8775	8775	0	5616	5616	0	6750	6750	0	4387	4387	0
	60	10800	10800	0	6804	6804	0	8775	8775	0	5616	5616	0	6750	6750	0	4387	4387	0
95	80	28080	8640	19440	17690	5443	12247	22815	7020	15795	14601	4492	10108	17550	5400	12150	11407	3510	7897
	75	19080	8640	10440	12020	5443	6577	15502	7020	8482	9921	4492	5428	11925	5400	6525	7751	3510	4241
	70	10980	8640	2340	6917	5443	1474	8921	7020	1901	5709	4492	1216	6862	5400	1462	4460	3510	950
	65	8640	8640	0	5443	5443	0	7020	7020	0	4492	4492	0	5400	5400	0	3510	3510	0
	60	8640	8640	0	5443	5443	0	7020	7020	0	4492	4492	0	5400	5400	0	3510	3510	0
90	80	28080	6480	21600	17690	4082	13608	22815	5265	17550	14601	3369	11232	17550	4050	13500	11407	2632	8774
	75	19080	6480	12600	12020	4082	7938	15502	5265	10237	9921	3369	6552	11925	4050	7875	7751	2632	5118
	70	10980	6480	4500	6917	4082	2835	8921	5265	3656	5709	3369	2340	6862	4050	2812	4460	2632	1828
	65	6480	6480	0	4082	4082	0	5265	5265	0	3369	3369	0	4050	4050	0	2632	2632	0
	60	6480	6480	0	4082	4082	0	5265	5265	0	3369	3369	0	4050	4050	0	2632	2632	0
85	80	28080	4320	23760	17690	2721	14968	22815	3510	19305	14601	2246	12355	17550	2700	14850	11407	1755	9652
	75	19080	4320	14760	12020	2721	9298	15502	3510	11992	9921	2246	7675	11925	2700	9225	7751	1755	5996
	70	10980	4320	6660	6917	2721	4195	8921	3510	5411	5709	2246	3463	6862	2700	4162	4460	1755	2705
	65	4320	4320	0	2721	2721	0	3510	3510	0	2246	2246	0	2700	2700	0	1755	1755	0
	60	4320	4320	0	2721	2721	0	3510	3510	0	2246	2246	0	2700	2700	0	1755	1755	0
80	75	19080	2160	16920	12020	1360	10659	15502	1755	13747	9921	1123	8798	11925	1350	10575	7751	877	6873
	70	10980	2160	8820	6917	1360	5556	8921	1755	7166	5709	1123	4586	6862	1350	5512	4460	877	3583
	65	3780	2160	1620	2381	1360	1020	3071	1755	1316	1965	1123	842	2362	1350	1012	1535	877	658
	60	2160	2160	0	1360	1360	0	1755	1755	0	1123	1123	0	1350	1350	0	877	877	0
	75	10980	0	10980	6917	0	6917	8921	0	8921	5709	0	5709	6862	0	6862	4460	0	4460
70	3780	0	3780	2381	0	2380	3071	0	3071	1965	0	1965	2362	0	2362	1535	0	1535	
60	0	0	0	0	0	0	0	0	0	0	0	0	0	0	0	0	0	0	

WERVP-\*3 WINTER HEATING PERFORMANCE (INDOOR DESIGN CONDITIONS 70°F DB)

AMBIENT O.D.	VENTILATION RATE					
	400 CFM 75% EFFICIENCY		325 CFM 76% EFFICIENCY		250 CFM 77% EFFICIENCY	
DB/°F	WVL	WHR	WVL	WVL	WVL	WVL
65	2160	1620	1755	1333	1350	1039
60	4320	3240	3510	2667	2700	2079
55	6480	4860	5265	4001	4050	3118
50	8640	6480	7020	5335	5400	4158
45	10800	8100	8775	6669	6750	5197
40	12960	9720	10530	8002	8100	6237
35	15120	11340	12285	9336	9450	7276
30	17280	12960	14040	10670	10800	8316
25	19440	14580	15795	12004	12150	9355
20	21600	16200	17550	13338	13500	10395
15	23760	17820	19305	14671	14850	11434

NOTE: Sensible performance only is shown for winter application.

LEGEND:

- VLT = Ventilation Load - Total
- VLS = Ventilation Load - Sensible
- VLL = Ventilation Load - Latent
- HRT = Heat Recovery - Total
- HRS = Heat Recovery - Sensible
- HRL = Heat Recovery - Latent
- WVL = Winter Ventilation Load
- WHR = Winter Heat Recovery

## /////// CABINET AND COIL OPTIONS

### Cabinet Finish Options

Unit models are available in Beige, White, Buckeye Gray, Desert Brown, Dark Bronze, stainless steel, and aluminum. Painted cabinet construction is comprised of 20 gauge Zinc coated steel. Parts are cleaned, rinsed, sealed, and dried before a polyurethane primer is applied. The cabinet coating is completed with a baked on textured enamel. The resulting finish is designed to withstand 1000 hours of salt spray tests per ASTM B117-03.

Stainless steel external cabinet construction is comprised of 316 grade materials. Stainless steel screws and fasteners are used in all externally exposed areas. A corrosion resistant coated fan blade and stainless steel condenser motor mount is provided.

Aluminum external cabinet construction is ASTM B 209 grade .06" thickness with a stucco appearance.

### Stainless Steel Cabinet Construction

Exterior Stainless Steel finish cabinets are often selected for corrosion and chemical resistance. Higher grades of stainless steel are often specified to meet the requirements of harsh environments. Units may not only be exposed to wind - blown dust, dirt, lint, and fibers but also may be exposed to corrosive agents. The Bard stainless steel unit offers a high quality stainless steel grade enclosure and fasteners for years of operation in these conditions.

#### Features:

- Sides, doors, grilles, back panels, and top are 316 grade stainless steel.
- Base, condenser partition, and fan shroud are 304 grade stainless steel.
- Stainless steel exterior cabinet screws, washers, nuts, and bolts, are used.
- Stainless steel outdoor motor mount and motor mount hardware.
- Compressor mounting hardware is stainless steel and hex no-spin rivet nuts are used in the unit base.
- Corrosion resistant coating is applied to fan blade.

Bard highly suggests units exposed to extremely harsh environments, high quantities, of airborne dirt and dust, or sprayed with water hose and splashing water be ordered with the Blank Off Plate (BOP) ventilation option unless codes require fresh air intake. The BOP ventilation option installs plates over the fresh air intake and exhaust openings.

### Green Fin Hydrophilic Evaporator Coils Standard On All Units

Bard WALL MOUNT products include a green protective coating applied to the aluminum fin stock used for the evaporator coil. The evaporator coil coating is hydrophilic (attracts water) and allows for proper condensate drainage along with mild corrosion protection. Resistance to corrosive agents include ammonia, sodium hydroxide, sodium chloride, acidic solutions and solvents.

Note: The green fin hydrophilic evaporator coil is not a replacement for technicoat coil coating. Green fin stock does provide additional coil protection, but technicoat is recommended for harsh indoor environments where strong acidic or alkalic chemicals are being used.



X—Beige



1—White



4—Gray



5—Desert



8—Bronze



S—Stainless



A—Aluminum



Hydrophilic Green Coil  
(standard)

## ////// CABINET AND COIL OPTIONS

### Evaporator and Condenser Coil TechniCoat Coating Options

All models utilize a copper/aluminum evaporator and condenser coil. An additional corrosion resistant TechniCoat 10-2™ coating may be ordered for the evaporator coil (option 1), condenser coil (option 2) or both evaporator and condenser coils (option 3). TechniCoat is a proprietary epoxy-modified phenolic dip coating. Total Immersion ensures complete coverage with no significant loss of thermal efficiency. The 4-step coating system consist of (1) a multi-step cleaning process, (2) chemical etch primer, (3) epoxy-modified phenolic, and (4) phenolic sealer. The result is a corrosion resistant coil that outperforms is less expensive, and is also nearly 3 times lighter than a copper finned coil. ASTM B117 salt spray tests conducted show over 4500 hours with “no fin corrosion or degradation.”

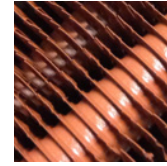

TechniCoat  
(optional)

### Cabinet Coating Options

Bard recommends unit coatings be used in applications that may be exposed to corrosive particulates in the airstream. These applications include wastewater treatment plants, gas and oil refinery operations, battery manufacturers, areas with Sulfur water, wineries, chemical plants, pulp and paper mills, and seacoast installations. Contact your Bard distributor for additional information regarding cabinet coating options.

### 4= Exterior Unit Cabinet & Condenser Section

The 4 option unit contains our corrosion resistance phenolic coated coils and a coated unit condenser section. By coating the condenser section, the copper tubing, motor mount, sheet metal parts, filter/drier and compressor housing in the condenser area are protected with a epoxy semi-gloss coating.

### 5= Exterior & Interior

The 5 option unit contains our corrosion resistance phenolic coated coils and cabinet is both internally and externally coated. By coating the interior and exterior of the unit, the copper tubing, motor mount, sheet metal parts, filter/drier, compressor housing, blower assembly, and any optional ventilation features are protected with a epoxy semi-gloss coating. This is the highest level of protection available. It is required for applications where the internal and external features of the unit are exposed to a high level of salt or corrosive chemicals.

## OPTIONAL DIP COATED EVAPORATOR AND CONDENSER COIL

Bard now offers TECHNICOAT AA, a robust dipped coating option for the evaporator and condenser coil. TECHNICOAT AA has passed all HVAC accelerated tests like salt spray, flexibility and SWAAT 3,000+ hours. It has been tested in the field in the most severe industrial exposure conditions, such as a coastal refinery in Saudi Arabia, mining facilities in central Africa, and various Pacific islands. TECHNICOAT AA did not show any deterioration after multiple years of function with coils directly exposed to such harsh environmental conditions. The TECHNICOAT AA coating system is based on modified acrylic waterborne binders with high elongation properties. Aluminum pigmentation has been added to establish exceptional heat transfer, chemical resistance, and UV blocking properties. Corrosion resistance reaches >10,000+ hours in ASTM B-117 and >3.120 hours in SWAAT testing. Coating is gray in color.

### TEMPERATURE RESISTANCE:

- Maximum up to 248°F (120°C), 480°F (250°C) peak exposure
- Minimum -40°F (-40°C)

### CHEMICAL RESISTANCE:

- Alkalines including Ammoniac solution, Potassium Hydroxide, Calcium Hydroxide, and Magnesium Hydroxide.
- Alcohols including Isopropanol, Butanol, Amyl Alcohol, Benzyl Alcohol, Diacetone Alcohol, Glycerine, Propanol, and Pentanol
- Aliphatic Hydrocarbons including White Spirit, Shellsol, Bitumen, Isopar G, and Paraffin.
- Amines including Triethanolamine, Aniline Sulphate, Hexamethylenetetraamine, Phenylamine, Triethylamine, and Methylamine.
- Inorganic Compounds including Hydrogen Carbonate, Hydrogen Sulfide, Nitrous Acid, Sulphuric Acid, and Selenic Acid.
- Aromatic Hydrocarbons including Xylene, Toluene, Asphalt, Anthracene, Benzapherene, Gumlac, Benzine, and Naphtha.
- Fuels and Oils including Diesel, Fuel Oil, Petrol, Super Petrol, Lubricating Oils, Kerosene, Spheric Oils, LPG, and Mineral Oil.
- Ethers including Enthrific Oils, Vegetable Oils, Butane, Acetylene, and Methane.
- Halogenated Hydrocarbons including Amyl Acetate, Propyl Acetate, Ethyl Oxalate, Butyl Acetate, and Butyl Propionate.
- Softeners including Palatinol C, Chloroparaffine 5XX, Dioctylphosphate, Desavin, Mesamol, and Dibutylphosphate.
- Organic Compounds including Benzoic Acid, Lactic Acid, Phenols, Fatty Acids, Malic Acid, and Picric Acid.
- Salts and water solutions including Sodium, Potassium, Calcium, Aluminum, Ammonium, Barium, Copper, Lead, and Lithium.
- Many other agents including Phosphor, Zinc, Glucose Syrup, Sulfur, Urea, Menthol, Antimony, Hydrogen, Rubber, and Shellac.

Contact your local Bard distributor or representative for a list of all chemicals and chemical resistance information.

### SPECIAL PROPERTIES:

- Anti-Odor
- Hydrophilic / Hydrophobic
- Anti-Corrosive

### EXPOSURE CONDITIONS INCLUDE:

Food Processing & Storage, Airports, Office Buildings, Hotels, Schools, Warehouses, Water Treatment, Breweries, Paper Mills, Refineries, Power Plants, Meat Processing Industries, Automotive Industries and other locations near shorelines and salt water.

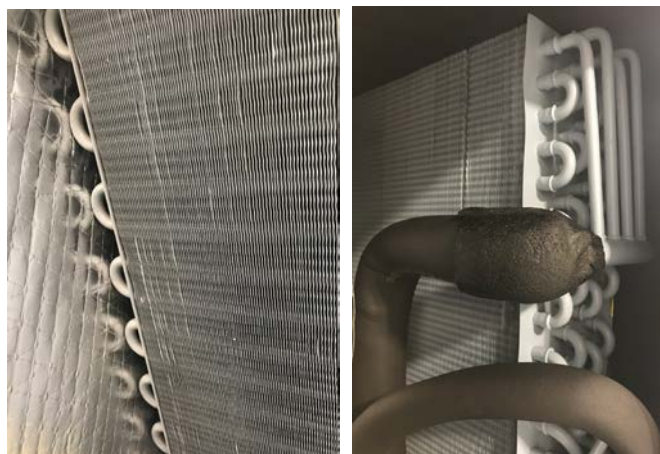

## WALL MOUNT™ FACTORY INSTALLED CONTROLS OPTIONS

Factory installed controls are provided by Bard to enhance a WALL MOUNT product before it is shipped. All WALL MOUNT products are shipped with a auto-reset high pressure switch and an auto-reset low pressure switch to help protect refrigeration components. A compressor control module with adjustable voltage protection, delay on make and break, and high/low pressure diagnostics is also standard

STD CODE UNIT	DEHUM UNIT CODE	DESCRIPTION OF FACTORY INSTALLED COMPONENTS
X	X	Hi Pressure Switch, Low Pressure Switch, Compressor Control Module.
E	E	Hi Pressure Switch, Low Pressure Switch, Compressor Control Module, <b>Low Ambient Control</b>
F	N/A	Hi Pressure Switch, Low Pressure Switch, Compressor Control Module, <b>Low Ambient Control, Dirty Filter Press. Switch</b>
J	N/A	Hi Pressure Switch, Low Pressure Switch, Compressor Control Module, <b>Low Ambient Control, Alarm Relay</b>
K	N/A	Hi Pressure Switch, Low Pressure Switch, Compressor Control Module, <b>Low Ambient Control, PTCR Start Kit</b>
M	N/A	Hi Pressure Switch, Low Pressure Switch, Compressor Control Module, <b>Low Ambient Control, Alarm Relay, PTCR Start Kit</b>
V	N/A	Hi Pressure Switch, Low Pressure Switch, Compressor Control Module, <b>Low Ambient Control, Alarm Relay, Discharge temperature sensor, Indoor Blower Airflow Press. Switch, Compressor Current Sensor, Dirty Filter Pressure Switch</b>

## WALL MOUNT™ FIELD INSTALLED KITS

Field installed kits provide accessories that can be installed in the field. Required components, wires, enclosures, screws, and instructions that are needed are provided within the kit.

CONTROL CODE	KIT PART NO.	UNITS USING KIT	DESCRIPTION OF FIELD INSTALLED KIT
E	<b>CMA-37 = 230V</b>	W18A, W18L, W24A, W24L	Low Ambient Control allows compressor cooling between 0°F and 50°F outdoor temp. - modulating
E	<b>CMA-38 = 460V</b>	W18A, W18L, W24A, W24L	Low Ambient Control allows compressor cooling between 0°F and 50°F outdoor temp. - modulating
E	<b>CMA-39</b>	W30A, W30L, W36A, W36L	Low Ambient Control allows compressor cooling between 0°F and 50°F outdoor temp. - fan cycling
NA	<b>CMC-15</b>	W18A, W18L, W24A, W24L, W30A, W30L, W36A, W36L	PTCR Start Kit. Increases starting torque by 2 to 3x. 230V-60hz-1 phase (A voltage) only. Cannot be used in combination with SK start kit
V	<b>CMA-40</b>	W18A, W18L, W24A, W24L, W30A, W30L, W36A, W36L	Kit Includes Alarm relay, Discharge temperature sensor, Indoor Blower Airflow Press. Switch, Compressor Current Sensor, Dirty Filter Pressure Switch*
NA	<b>SK-111</b>	W18A, W18L, W24A, W24L, W30A, W30L, W36A, W36L	Start Capacitor and Potential Relay Start Kit. Increases starting torque by 9x. 230V-60hz-1 phase (A voltage) only. Cannot be used in combination with CMC start kit
NA	<b>CMA-14</b>	W18A, W18L, W24A, W24L, W30A, W30L, W36A, W36L	Outdoor Thermostat Kit used to disable compressor cooling below 50°F outdoor temp. Adjustable between 50° and 0°F
NA	<b>CMC-31</b>	W18A, W18L, W24A, W24L, W30A, W30L, W36A, W36L	Dirty Filter Kit
NA	<b>CMC-34</b>	W18A, W18L, W24A, W24L, W30A, W30L, W36A, W36L	Alarm Relay Kit

\* CMA-40 Kit does not include low ambient control. Low ambient control can be ordered separately either as factory installed or as a kit.

## ////// 24VAC LOW VOLTAGE TERMINAL DESIGNATIONS

Bard WALL MOUNT products provide 24VAC power to controllers and thermostats. They also are able to receive 24VAC signals from a controlling device. The V controls option provides additional sensors for use with a field supplied DDC controls systems. The information below provides terminal designations and how they are used in the WALL MOUNT unit. More information on low voltage connections and operational sequences is provided in the unit installation manual.

Terminal	Unit	Description
<b>R</b>	All Units	24VAC low voltage output (HOT Terminal)
<b>RT</b>	All Units	RT terminal has jumper to R terminal. When jumper is removed, R and RT can be used with normally closed contacts for fire/smoke detector for unit shutdown.
<b>C</b>	All Units	Ground Terminal
<b>G</b>	All Units	Indoor fan input
<b>Y1</b>	All Units	1st Stage cooling input. Economizer stage when used. Balanced Climate stage when used.
<b>Y2</b>	All Units	2nd Stage cooling input. Compressor cooling stage when Econ or Balanced Climate is used.
<b>B/W1</b>	All Units	1st Stage electric heat
<b>W2</b>	All Units	2nd State electric heat. Jumper between W1 and W2 must be removed for staged heat
<b>A</b>	Vent option units only	Ventilation option input. Calls for occupied vent air intake for CRV, ERV, ECON
<b>D</b>	Dehum. units only	Dehumidification input on units equipped with mechanical reheat dehumidification
<b>L</b>	All Units	24VAC Alarm active output
<b>1</b>	C, J, M, V Control Opt.	Alarm relay Normally Closed Contract
<b>2</b>	C, J, M, V Control Opt.	Alarm relay Normally Open Contact
<b>3</b>	C, J, M, V Control Opt.	Alarm Relay Common Contact
<b>9</b>	V Controls Option Only	Discharge Air Sensor, 10K ohm
<b>10</b>	V Controls Option Only	Discharge Air Sensor, 10K ohm
<b>11</b>	G, V Control Options	Filter Switch, Normally Open Contacts
<b>12</b>	G, V Control Options	Filter Switch, Normally Open Contacts
<b>13</b>	V Controls Option Only	Blower Airflow Switch, Normally Open Contacts
<b>14</b>	V Controls Option Only	Blower Airflow Switch, Normally Open Contacts
<b>15</b>	V Controls Option Only	Compressor Current Sensor, Normally Open Contacts
<b>16</b>	V Controls Option Only	Compressor Current Sensor, Normally Open Contacts

## //////// OPTIONAL CONTROLS AND KIT COMPONENT DEFINITIONS

**Hi Pressure Control (HPC)** - The high pressure control provides a means of protecting the refrigeration circuit when high system pressures occur. It is a auto-reset device that is connected to the Compressor Control Module. When activated, the compressor is disabled until pressures reach an acceptable level. If activated twice in the same cooling call, compressor operation is locked out until the cooling call is interrupted.

**Low Pressure Control (LPC)** - The low pressure control provides a means of protecting the refrigeration circuit when extremely low system pressures occur. It is a auto-reset device that is connected to the Compressor Control Module. When activated, the compressor is disabled until pressures reach an acceptable level.

**Compressor Control Module (CCM)** - The compressor control module locks out compressor operation to protect the refrigeration system based on signals from the hi and low pressure switches. It provides diagnostics to indicate when a refrigerant pressure event occurs, and also sends a signal to the alarm relay. Low incoming unit power protection suspends compressor operation when incoming voltage is too low. Suspending compressor operation avoids reverse scroll operation. The low voltage feature is adjustable or can be disabled. An adjustable delay on break timer is provided. Delay on make is 2 mins. plus 10% of delay on break setting.

**Alarm Relay (ALR)** - The alarm relay provides a set of NO and NC pilot duty contacts that operate when the compressor control module locks out compressor operation because of a high or low system refrigerant pressure event.

**Low Ambient Control (LAC)** - The low ambient control is a pressure switch that is attached to the liquid line of the system, and monitors high side system pressure. Operation of the LAC occurs as outdoor temperatures drop below 60°F. LAC operation cycles the condenser fan on/off based on outdoor temperature. An outdoor temperature sensor and an evaporator freeze protection thermostat is supplied with all units that get a low ambient control. The outdoor sensor disables Balanced Climatemode (if enabled) when the outdoor temperature drops below 50°F. This deters potential evaporator coil freezing issues. The freeze protection thermostat interrupts compressor operation and continues to run the indoor blower to raise the evaporator coil temperature.

**Crankcase Heater (CCH)** - The heater is a belly band that is installed around the base of the compressor that applies heat when the refrigeration system is not operational. This heat is meant to prevent refrigerant oil migration when the unit is not running. Normal scroll compressor use does not require the use of the CCH, and this option is only recommended for northern areas of the US and Canada with extreme cold operation. Field Install Option Only.

**Outdoor Thermostat (ODT)** - The outdoor thermostat measures outdoor temperatures and includes relay contacts (NO). The relay is located on the outer control panel and the sensor bulb is mounted to the fan shroud in the outdoor condenser section. When wired into the cooling signal inside the control panel, compressor operation can be disabled when temperatures are below the adjustable setting. Adjustment range is 0°F to 50°F.

**PTCR Start Kit** - PTCR (Precision Temperature Coefficient Resistor) start kit includes the start device and wires needed for installation. The device is located inside the unit control panel near the compressor capacitor and provides an increase in starting torque. The PTCR Start Kit is not normally required when a clean, stable power source is available for the unit. The kit can only be used in 230 Volt single phase units.

**Start Capacitor and Potential Relay Start Kit** - The kit includes a start capacitor and relay that is energized during startup of the compressor. The capacitor, relay, and needed wires are provided in a metal enclosure that is field installed in the outdoor section attached to the back. The Start Capacitor Kit is not normally required when a clean, stable power source is available for the unit. The kit can only be used in 230 Volt single phase units. Start capacitor kit cannot be used with the PTCR start kit installed.

**Dirty Filter Switch Indicator (DFS)** - The switch is adjustable and measures pressure drop across the unit filter surface. When pressure drop is higher than the switch setting NO and NC contacts are provided to indicate the filter needs to be serviced.

**Discharge Air Sensor** - The discharge air sensor provides a temperature reading of the supply air leaving the unit. The sensor is a 10K OHM @ 77°F measuring device. It is installed in the supply airstream in the heater bracket.

**Airflow Switch** - The airflow switch measures the pressure differential between the blower inlet and outlet. It is located directly above the blower partition. Relay contacts (NO) are provided for V controls option that indicates the indoor blower assembly needs to be serviced. The F controls option has indicator light only.

**Compressor Current Sensor** - The compressor current sensor indicates when the compressor is operational by measuring Amp draw. It is located inside the unit control panel. Relay contacts (NO) are provided to indicate the compressor is not operating.

# ////// CABINET AND CLEARANCE DIMENSIONS - WA RIGHT SIDE CONTROL PANEL UNITS

## CLEARANCES REQUIRED FOR SERVICE ACCESS AND ADEQUATE CONDENSER INLET AIRFLOW

MODELS	LEFT SIDE	RIGHT SIDE
W18AB, W24AB, W30AB, W36AB	15"	20"

**NOTE:** For side-by-side installation of two (2) WA models, there must be 20" between units. This can be reduced to 15" by using a WL model (left side compressor and controls) for the left unit and WA (right side compressor and controls) for right unit.

- 1.) Follow all national, state, and local codes and regulations regarding the installation of heating and cooling equipment regarding Single Packaged Vertical Units (SPVU) including electrical access clearances.
- 2.) Field ventilation installation with the unit installed requires 40" on the left or right side of the unit.
- 3.) Bard recommends a minimum of 10 ft. between the unit front condenser air outlet and solid objects including fences, walls, bushes, and other airflow obstructions.
- 4.) Bard recommends a minimum of 15 ft. between the condenser air outlets of 2 units that are facing each other.
- 5.) Bard recommends a minimum clearance of 4" under the unit cabinet for condenser defrost drainage during heat pump operation.

## MINIMUM CLEARANCES REQUIRED TO COMBUSTIBLE MATERIALS

MODELS ①	SUPPLY AIR DUCT FIRST THREE FEET	CABINET
W18AB, W24AB	0"	0"
W30AB, W36AB	1/4"	0"

① Refer to the Installation Manual for more detailed information.

## DIMENSIONS OF W18-36A BASIC UNIT FOR ARCHITECTURAL & INSTALLATION REQUIREMENTS (NOMINAL)

MODEL	WIDTH (W)	DEPTH (D)	HEIGHT (H)	SUPPLY		RETURN																
				A	B	C	D	E	F	G	I	J	K	L	M	N	O	P	Q	R	S	T
W18AB W24AB	33.300	17.125	74.563	7.88	19.88	11.88	19.88	35.00	10.88	29.75	20.56	30.75	32.06	33.25	31.00	2.63	34.13	26.06	10.55	3.94	12.00	9.00
W30AB W36AB	38.200	17.125	74.563	7.88	27.88	13.88	27.88	40.00	10.88	29.75	17.93	30.75	32.75	33.25	31.00	2.75	39.13	26.75	9.14	3.94	12.00	9.00

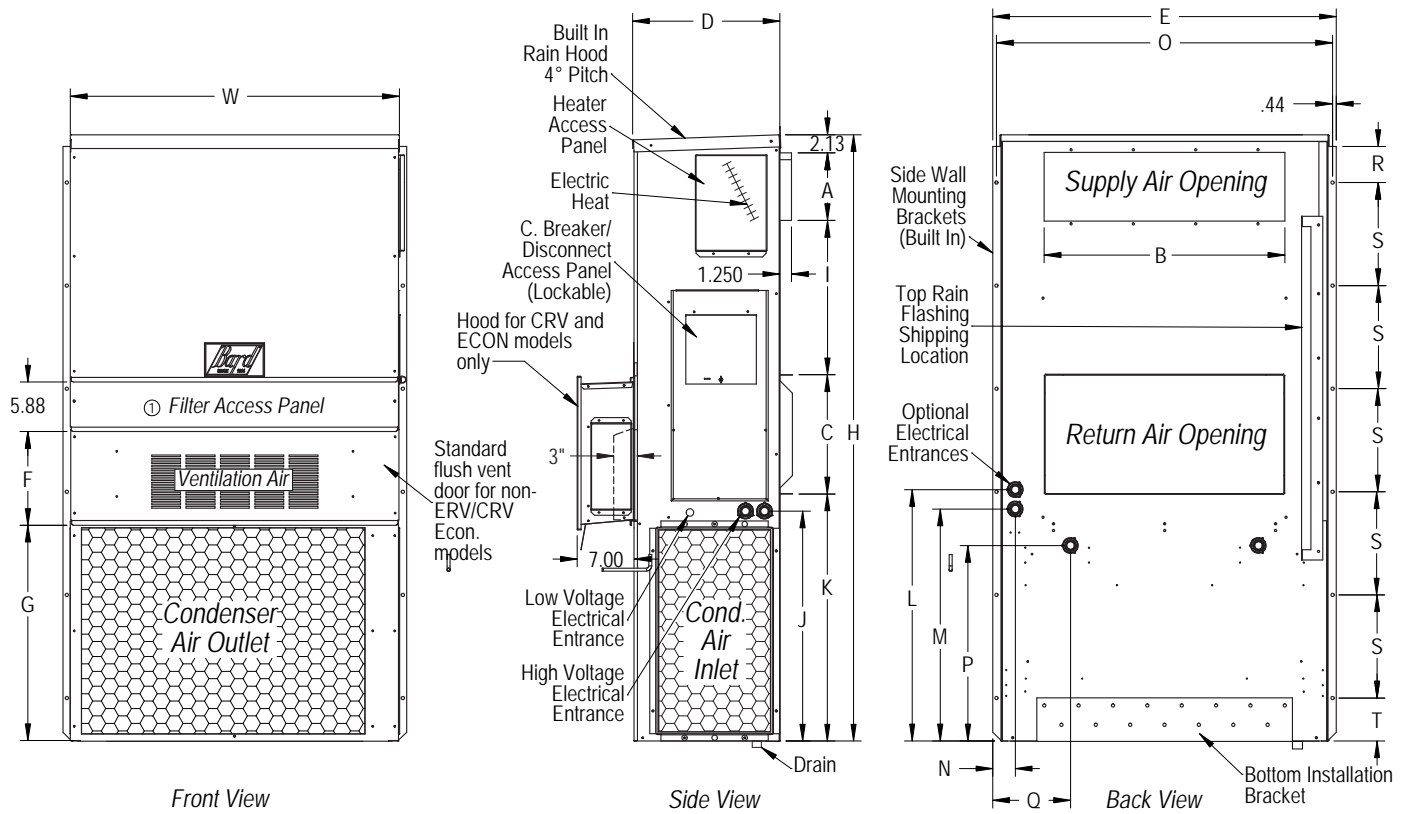

MIS-3796

# ////// CABINET AND CLEARANCE DIMENSIONS - WL LEFT SIDE CONTROL PANEL UNITS

## CLEARANCES REQUIRED FOR SERVICE ACCESS AND ADEQUATE CONDENSER INLET AIRFLOW

MODELS	LEFT SIDE	RIGHT SIDE
W18LB, W24LB, W30LB, W36LB	20"	15"

**NOTE:** For side-by-side installation of two (2) WL models, there must be 20" between units. This can be reduced to 15" by using a WL model (left side compressor and controls) for the left unit and WA (right side compressor and controls) for right unit.

- 1.) Follow all national, state, and local codes and regulations regarding the installation of heating and cooling equipment regarding Single Packaged Vertical Units (SPVU) including electrical access clearances.
- 2.) Field ventilation installation with the unit installed requires 40" on the left or right side of the unit.
- 3.) Bard recommends a minimum of 10 ft. between the unit front condenser air outlet and solid objects including fences, walls, bushes, and other airflow obstructions.
- 4.) Bard recommends a minimum of 15 ft. between the condenser air outlets of 2 units that are facing each other.
- 5.) Bard recommends a minimum clearance of 4" under the unit cabinet for condenser defrost drainage during heat pump operation.

## MINIMUM CLEARANCES REQUIRED TO COMBUSTIBLE MATERIALS

MODELS ①	SUPPLY AIR DUCT FIRST THREE FEET	CABINET
W18LB, W24LB	0"	0"
W30LB, W36LB	1/4"	0"

① Refer to the Installation Manual for more detailed information.

## DIMENSIONS OF W18-36L BASIC UNIT FOR ARCHITECTURAL & INSTALLATION REQUIREMENTS (NOMINAL)

MODEL	WIDTH (W)	DEPTH (D)	HEIGHT (H)	SUPPLY		RETURN		E	F	G	I	J	K	L	M	N	O	P	Q	R	S	T
				A	B	C	B															
W18LB W24LB	33.300	17.125	74.563	7.88	19.88	11.88	19.88	35.00	10.88	29.75	20.56	30.75	32.06	33.25	31.00	2.63	34.13	26.06	10.55	3.94	12.00	9.00
W30LB W36LB	38.200	17.125	74.563	7.88	27.88	13.88	27.88	40.00	10.88	29.75	17.93	30.75	32.75	33.25	31.00	2.75	39.13	26.75	9.14	3.94	12.00	9.00

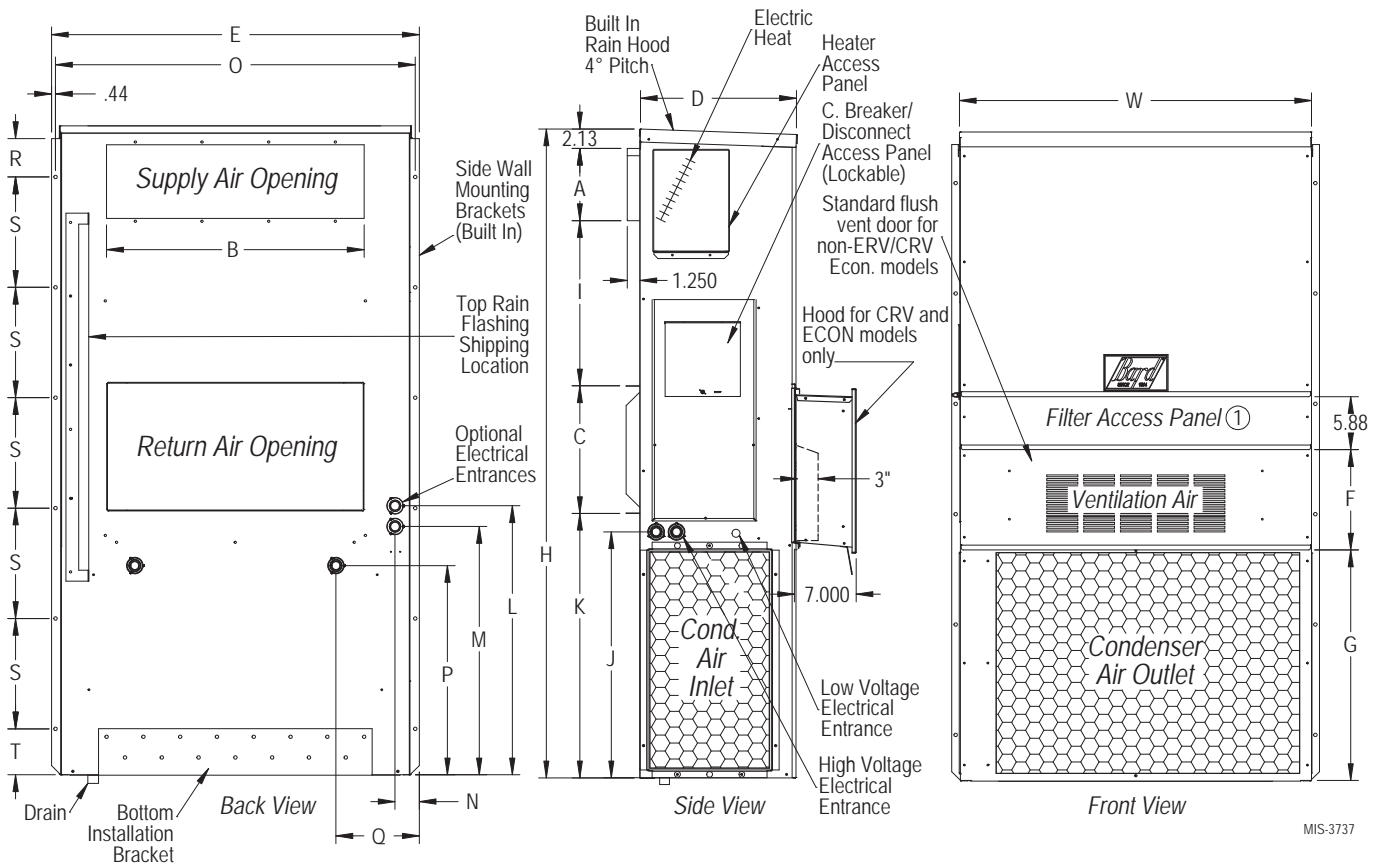

MIS-3737

## ////// WALL CURB ACCESSORIES

Optional wall curb accessories are available to help reduce vibration through the outer wall surface or to use existing wall openings when replacing equipment. Follow all static pressure airflow requirements, safety and installation guidelines in the instructions provided with the curb and WALL MOUNT products.

CURB	UNITS USING CURB	DESCRIPTION
<b>WMICF2-*</b>	W18A, W18L, W24A, W24L	Provides vibration isolation for reduced sound transmission through wall
<b>WMICF3-*</b>	W30A, W30L, W36A, W36L	Provides vibration isolation for reduced sound transmission through wall
<b>WWC3-*</b>	W30A, W30L, W36A, W36L	Install to use with existing wall openings. Wall openings must provide sufficient airflow

\* Color Option

## ////// INDOOR SOUND REDUCTION ACCESSORIES

Optional sound accessories are available to help reduce sound transmission from the supply and return openings inside the indoor area. Follow all static pressure airflow requirements, safety and installation guidelines in the instructions provided with the accessories and WALL MOUNT products.

ACCESSORY	UNITS USING ACCESS.	DESCRIPTION
<b>WAPR11-*</b>	W30A, W30L, W36A, W36L	Acoustical return air plenum that offsets the return air path. Air intake at floor level

\* Color Option

## ////// NON-DUCTED SUPPLY AND RETURN GRILLES

Supply and return louver grilles are of a brushed aluminum finish. 2" flange versions are recommended for standard installations to allow grille attachment when large wall openings are present. Return filter grilles are available for filter access from an indoor area. Filter grilles do not include a filter, and are not recommended for unit with ventilation due to filter location. A manual damper return grille is available for W30 and W36 models. The manual damper is adjustable, and is only recommended for installations where increased return duct static pressure is required.

GRILLE NO.	UNITS USING GRILLE	DESCRIPTION OF LOUVER GRILLE
<b>SG-2W</b>	W18A, W18L, W24A, W24L	8" x 20" with 2" Flange 4 way deflection supply grille. <b>Use for standard installations</b>
<b>SG-3W</b>	W30A, W30L, W36A, W36L	8" x 28" with 2" Flange 4 way deflection supply grille. <b>Use for standard installations</b>
<b>RG-2W</b>	W18A, W18L, W24A, W24L	12" x 20" with 2" Flange return grille. <b>Use for standard installations.</b>
<b>RG-3W</b>	W30A, W30L, W36A, W36L	12" x 28" with 2" Flange return grille. <b>Use for standard installations.</b>
<b>RFG-2W</b>	W18A, W18L, W24A, W24L	12" x 20" with 2" Flange return grille with filter bracket.
<b>RFG-3W</b>	W30A, W30L, W36A, W36L	12" x 28" with 2" Flange return grille with filter bracket.
<b>RGD-3</b>	W30A, W30L, W36A, W36L	12" x 28" with 1" Flange return grille. Manual damper used to restrict return air.

## ////// NON-DUCTED SUPPLY GRILLES - SPREAD AND THROW CHARACTERISTICS

One of the most important setup procedures for non-ducted supply applications is to adjust the 4 way supply grille blade positions. Placement of equipment, occupants, the thermostat, and room size can all play an important role in deciding how the conditioned supply air must be directed in an indoor area. The chart below may be used as a reference tool to help with this process.

SUPPLY GRILLE	AIRFLOW CFM	DEFLECTION	VELOCITY	TOTAL PRESSURE	THROW
SG-2W	800 CFM	0°	1053	.076" WC	37-52 ft.
		22.5°	1143	.1" WC	28-40 ft.
		45°	1428	.162" WC	20-29 ft.
	865 CFM	0°	1138	.054" WC	40-55 ft.
		22.5°	1236	.075" WC	31-42 ft.
		45°	1544	.113" WC	21-30 ft.
SG-3W	885 CFM	0°	852	.054" WC	37-54 ft.
		22.5°	1075	.075" WC	35-49 ft.
		45°	1162	.113" WC	21-30 ft.
	1285 CFM	0°	1237	.108" WC	42-66 ft.
		22.5°	1359	.147" WC	35-50 ft.
		45°	1687	.249" WC	25-37 ft.

## ////// CONTROLLER, THERMOSTAT, HUMIDISTAT AND CO2 VENTILATION CONTROL OPTIONS

Bard provides a wide variety of controllers for equipment cooling, thermostats, for equipment and comfort cooling, humidistats for dehumidification units, and CO2 sensors for ventilation control. Lockable thermostat covers are available for applications where security or supervisory control is desired.

CONTROLLER	OPERATION	DESCRIPTION
<b>MC-4002</b>	2 Unit Lead/Lag Controller	Standard Lead/Lag Controller with remote alarming capability.
<b>TEC40</b>	4 Unit Controller	Easy to use 4 unit controller with staged operation.

THERMOSTAT	OPERATION	DESCRIPTION
<b>8403-060</b>	3 Heat/3 Cool	Programmable or Nonprogrammable, ventilation output, dehumidification operation
<b>8403-089</b>	1 Heat/1 Cool	Temp. Settings per Day 4, 2, 1, 0 Programs per Week 7, 5-2, 5-1-1 or Nonprogrammable
<b>8403-090</b>	2 Heat/2 Cool	Temp. Settings per Day 4, 2, 1, 0 Programs per Week 7, 5-2, 5-1-1 or Nonprogrammable
<b>8403-091</b>	1 Heat/1 Cool	Easy to use, Nonprogrammable. FEMA use
<b>8403-092</b>	2 Heat/2 Cool	Programmable or Nonprogrammable, ventilation output, Wi-Fi

HUMIDISTAT	OPERATION	DESCRIPTION
<b>8403-038</b>	Humidity %RH	Easy to use w/SPDT switching. Ratings: Pilot duty 50VA @24V, 120VA @ 120/240V
<b>8403-047</b>	Humidity %RH	Electronic with display, EEPROM memory, lockable keypad, humidity sensor calibration

CO2 CONTROL	OPERATION	DESCRIPTION
<b>S8403-067</b>	CO2 PPM	CO2 ventilation control with digital display. On/Off or modulating ventilation operation

THERMOSTAT COVER*	SIZE	DESCRIPTION
<b>8405-003</b>	(Inside) 5-1/16" H x 6-1/16" W (Outside) 6-1/2" H x 7-1/2" W x 2-15/16" D	Clear acrylic with ventilation. Fits all thermostats except 8403-060
<b>8405-005</b>	(Inside) 5-7/8" H x 8-3/8" W (Outside) 7-1/4" H x 9-3/4" W x 3-3/8" D	Clear acrylic with ventilation. Fits all thermostats.
<b>8405-006</b>	(Inside) 5-1/16" H x 6-1/16" W (Outside) 6-3/8" H x 7-3/8" W x 2-7/8" D	Beige painted steel cover with ventilation. Fits all thermostats except 8403-060
<b>8405-007</b>	(Inside) 5-7/8" H x 8-3/8" W (Outside) 7-1/8" H x 9-5/8" W x 3-1/4" D	Beige painted steel cover with ventilation. Fits all thermostats.

\* Thermostat covers include ventilation, but may effect temperature control reaction time. If security control lockout is needed, the 8403-060 thermostat provides input control lockout features.



Bard Manufacturing Company, Inc.  
1914 Randolph Dr., Bryan, OH 43506  
419-636-1194

[www.bardhvac.com](http://www.bardhvac.com)

**Due to our continuous product improvement policy, all specifications subject to change without notice.**