

Duo-THERM®

by Dometic

RECORD THIS UNIT INFORMATION FOR FUTURE REFERENCE:

Model Number _____
Serial Number _____
Date Purchased _____

600 Series Penguin
579 Series BRISK AIR
590 Series QUICK COOL
595 Series QUICK COOL
Roof Top Air Conditioner
USED WITH
Part No. 3106481.009
Electronic Kit Control

USA
SERVICE OFFICE
The Dometic Corp.
509 So. Poplar St.
LaGrange, IN 46761

CANADA
Dometic Dist.
866 Langs Dr.
Cambridge, Ontario
CANADA N3H 2N7

**THIS UNIT IS DESIGNED FOR OEM INSTALLATION
ALL INITIAL INSTALLATIONS MUST BE APPROVED BY THE SALES DEPT.**



**UNDERWRITERS
LABORATORIES**
INC.®
LISTED
637G



CERTIFIED
LR23565

WARNING

Improper installation, adjustment, alteration, service or maintenance can cause injury or property damage. Refer to this manual. For assistance or additional information consult a qualified installer or service agency.

AVERTISSEMENT

Une mauvaise installation, de mauvais réglages, modifications ou opérations d'entretien peuvent endommager les biens ou même blesser. Se reporter à la notice. Pour obtenir de l'aide ou des renseignements complémentaires, consulter un installateur qualifié ou une agence de service après-vente.

INSTALLATION & OPERATING INSTRUCTIONS

MODELS

57908.521	59016.621
57912.621	59016.626
57915.421	59516.501
57915.426	59516.506
57915.521	59516.601
57915.526	59516.606
57915.621	600312.321
57915.626	600312.421
59016.521	600315.321
59016.526	600315.421

SPECIFICATIONS

MODEL NO.	57908.521	57912.621	57915.421 57915.426	57915.521 57915.526	57915.621 57915.626	59016.521 59016.526 59016.621 59016.626	59516.501 59516.506 59516.601 59516.606	600312.321	600312.421	600315.321	600315.421
Nominal Capacity (BTU/HR) *	7,100	11,000	13,500	13,500	13,500	15,000	15,000	11,000	11,000	13,500	13,500
Electrical Rating	115 VAC, 60 Hz., 1 ph.										
Compressor Rated Load Amps	6.6	8.5	11.5	12.1	11.0	12.9	12.9	9.5	10.7	12.4	11.5
Fan Motor Rated Load Amps	2.5	2.5	2.5	2.5	2.5	2.5	2.5	3.1	3.1	3.1	3.1
Compressor Locked Rotor Amps	34.0	48.3	50.0	59.0	54.4	71.0	71.0	53.0	50.0	60.0	50.0
Fan Motor Locked Rotor Amps	5.8	5.8	5.8	5.8	5.8	6.0	6.0	8.8	8.8	8.8	8.8
Heater Amps/Watts @ 120VAC	NOT AVAILABLE ON THESE MODELS					12.7/1530		NOT AVAILABLE			
SCFM-High Speed Max./Min.	325 / 250					350/250		335/250			
Total Static - Min/Max.	0.55 / 0.90" W.C.					0.40/1.10		0.12/0.65" W.C.			
Refrigerant R22 Charge (Oz.)	17.0	16.0	13.5	16.0	16.0	26.5	31.0	16.5	16.0	15.5	17.0
Minimum Wire Size **	12 AWG Copper Up to 24 ft.										
AC Circuit Protection	20 Amp Time Delay Fuse or 20 Amp HACR Circuit Breaker										
DC Circuit Protection	Installation must comply with all National, State, Providence, and/or local Electrical Codes										
Installed Weight (Pounds)	75	94	100	94	94	101	102	95	101	96	102
Minimum Generator Size ***	1 Unit	2.5 KW		3.5 KW			2.5 KW		3.5 KW		
	2 Units	4.0 KW		5.0 KW			4.0 KW		5.0 KW		

* Maximum unit performance achieved at full rated voltage.

** For distances over 24 ft. consult the National Electrical Code.

*** The Dometic Corporation gives **GENERAL** guidelines for generator requirements. These guidelines come from experiences people have had in actual applications. When sizing the generator, the total power usage of your recreational vehicle must be considered. Also keep in mind generators lose power at high altitudes and from lack of maintenance.

1. GENERAL INFORMATION

A. This air conditioner is designed for:

1. Installation on a recreational vehicle at the time the vehicle is manufactured.
2. Mounting on the roof of a recreational vehicle.
3. Connection to an air distribution system located in the ceiling/roof cavity of the recreational vehicle.
4. Roof construction with rafters/joists on minimum of 16 inch centers.
5. Minimum of 2.00 inches and maximum of 5.50 inches distance between roof to ceiling of recreational vehicle. Alternate installation methods will allow for roofs more than 5.50 inches thick.

B. The ability of the air conditioner to maintain the desired inside temperature depends on the heat gain of the RV. Some preventative measures taken by the occupants of the RV can reduce the heat gain and improve the performance of the air conditioner. During extremely high outdoor temperatures, the heat gain of the vehicle may be reduced by:

1. Parking the RV in a shaded area
2. Using window shades (blinds and/or curtains)
3. Keeping windows and doors shut or minimizing usage
4. Avoiding the use of heat producing appliances

Starting the air conditioner early in the morning and giving it a "head start" on the expected high outdoor ambient will greatly improve its ability to maintain the desired indoor temperature.

For a more permanent solution to a high heat gain, accessories like A&E outdoor patio and window awnings will reduce heat gain by removing the direct exposure to the sun. They also add a nice area to enjoy company during the cool of the evening.

C. Condensation

NOTE

The manufacturer of this air conditioner will not be responsible for damage caused by condensed moisture on ceilings or other surfaces. Air contains moisture and this moisture tends to condense on cold surfaces. When air enters the RV, condensed moisture may appear on the ceiling, windows, metal parts, etc. The air conditioner removes this moisture from the air during normal operation. Keeping doors and windows closed when this air conditioner is in operation will minimize condensed moisture on cold surfaces.

2. PRECAUTIONS

WARNING

IMPROPER INSTALLATION MAY DAMAGE EQUIPMENT, COULD ENDANGER LIFE, CAUSE SERIOUS INJURY AND/OR PROPERTY DAMAGE.

- A. Read Installation and Operating Instructions carefully before attempting to start your air conditioner.
- B. The Dometic Corporation will not be liable for any damages or injury incurred due to failure in following these instructions.
- C. Installation must comply with the National Electrical Code and any State or Local Codes or regulations.
- D. DO NOT add any devices or accessories to this air conditioner except those specifically authorized by Dometic.
- E. This equipment must be serviced by qualified personnel and some states require these people to be licensed.

3. CONTROL DESCRIPTION

The Dometic Air Conditioner Control is a sophisticated electronic control using the latest electronic technology. It consists of a **Comfort Control Center (Part No. 3106363.007)** and an **Electronic Control Box (Part No. 3106481.009)**. The **Comfort Control Center** is the operator interface. It contains a liquid crystal display (LCD) and the operator switches and buttons. The **Electronic Control Box** contains the interface circuitry for the air conditioner.

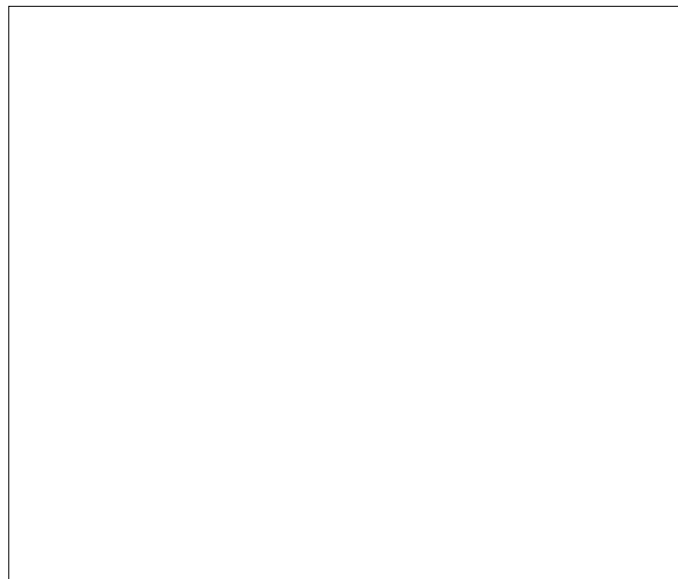

A. COMFORT CONTROL CENTER

- 1) The LCD indicates the mode of operation, the temperature Setpoint and the fan speed.
 - a. The possible modes of operation are **OFF, FAN ONLY, COOL, FURNACE** and **HEAT STRIP**.

- b. The possible fan speeds are **LOW, MED, HIGH** and **AUTO**.
- c. The temperature **Setpoint** range is 40 to 99 degrees Fahrenheit.
- d. In the case of multiple zones, the zone will indicate **ZONE 1, 2, 3** or **4**.

- 2) The mode of operation is selected by momentarily depressing the **MODE** pushbutton.
- 3) The fan speed is selected by momentarily depressing the **FAN** pushbutton.
- 4) The temperature **Setpoint** is adjusted by momentarily depressing the **up** or **down** arrow.
- 5) An ON/OFF switch is provided on the lower right edge of the **Comfort Control Center**.
- 6) In the event that a **Remote Temperature Sensor (Part No.)** is not used, the **Comfort Control Center** temperature sensor is used. In this case, the **Comfort Control Center** must be treated as a wall thermostat and appropriately mounted in the RV.
- 7) The **Comfort Control Center** is connected to the **Electronic Control Box** via a 4-conductor telephone cable using telephone RJ-11 connectors.

B. ELECTRONIC CONTROL BOX

- 1) The **Electronic Control Box** contains relays for switching the various fan speeds, compressor and furnace.
- 2) There are wires protruding from the **Box** for connection to DC power, furnace thermostat wires and an Energy Management System.
- 3) A **Freeze Control Sensor** connects to the **Electronic Control Box** to allow for the prevention of freezing coils. This sensor lead is inserted into the Box and plugged into a connector for that purpose.
- 4) A **Remote Temperature Sensor** may be connected to the **Electronic Control Box** using the **Remote Sensor Kit** (Part No. 3106486.008).

4. OPERATING INSTRUCTIONS

A. FAN ONLY MODE OPERATION

- 1) Place the Power switch to the **ON** position.
- 2) Momentarily depress the **MODE** pushbutton until **FAN ONLY** indicator on the Liquid Crystal Display (LCD) is illuminated.

- 3) Momentarily depress the **FAN** pushbutton until the desired fan speed indicator (**LOW, MED, HIGH, AUTO**) is illuminated.
- 4) After 5 seconds the selected fan speed will come on.

B. COOLING MODE OPERATION

- 1) Momentarily depress the **MODE** pushbutton until the **COOL** indicator on the LCD is illuminated.
- 2) Momentarily depress the UP or DOWN pushbutton until the desired temperature Setpoint is displayed.
- 3) The compressor will come on after a delay of approximately 2 minutes.
- 4) The compressor will cycle OFF per the temperature **Setpoint** displayed. The compressor will restart in approximately two minutes after the control senses the need for cooling. The fan will:
 - a) Continue to operate in the single selected fan speed if the **AUTO** fan speed is not selected.
 - b) Cycle OFF and ON with the compressor if the **AUTO** fan speed is selected.

C. FURNACE MODE OPERATION (If so equipped)

- 1) Momentarily depress the **MODE** pushbutton until the **FURNACE** indicator on the LCD is illuminated.
- 2) Momentarily depress the **UP** or **DOWN** pushbutton until the desired temperature **Setpoint** is displayed.
- 3) The furnace will cycle ON and OFF to provide the selected temperature.
- 4) The A/C fan will not operate in the **FURNACE** mode.

D. HEAT STRIP MODE OPERATION (If so equipped)

- 1) Momentarily depress the **MODE** pushbutton until the **HEAT STRIP** indicator on the LCD is illuminated.
- 2) Momentarily depress the UP or DOWN pushbutton until the desired temperature Setpoint is displayed.
- 3) The electric heat strip will cycle ON and OFF per the temperature Setpoint displayed. The fan will:
 - a. Continue to operate in the selected fan speed if the **AUTO** fan speed is not selected.
 - b. Cycle OFF and ON with the heat strip if the **AUTO** fan speed is selected.

- 4) The fan will operate in **LOW, MED** or **AUTO**. **HIGH** speed is not selectable in the **HEAT STRIP** mode. The fan speed selected while in **AUTO** is **LOW**.

E. SPECIAL CONTROL FEATURES

- 1) **AUTO FAN:** When selected, fan will:
 - a. If in **COOL** mode, automatically select the fan speed depending upon the difference between the temperature **Setpoint** and the room temperature.
For a temperature difference of:

8 deg. or more	-	Fan operates on HIGH
4 to 8 deg.	-	Fan operates on MED
4 deg. or below	-	Fan operates on LOW
 - b. If in **HEAT STRIP** mode, automatically select **LOW** fan speed.
 - c. If in **FAN ONLY** mode, automatically select **LOW** fan speed.

2) REFRIGERANT COMPRESSOR TIME DELAY:

The compressor will always have a delay in starting of approximately two minutes any time it is required to begin the cooling cycle.

3) POWER INTERRUPTION

In the event that power to the air conditioner or control is interrupted, the system will restart in the condition previously set by the user.

4) ZONE CONTROL

In the event of a multiple zone installation, the **MODE** of operation for each zone may be independently set. If there are multiple zones, the **LCD** indicators **ZONE** and **1,2,3** or **4** will be illuminated. To change from one zone to another, simultaneously depress the **FAN** and **MODE** pushbuttons. The indicator will change the zone data displayed. To program each zone, simply repeat the programming steps above in each zone. Note, however, that the system will prevent operating **HEAT** and **COOL** at the same time.

5. MAINTENANCE

AIR FILTER: Periodically remove the return air filter. Wash the filter with soap and warm water; let dry and then reinstall or replace as required.

NOTE: Never run the air conditioner without return air filter in place. This may plug the unit evaporator coil with dirt and may substantially affect the performance of the unit.

6. SERVICE - Unit Does Not Operate

If your unit fails to operate or operates improperly, check the following before calling your service center.

- If your RV is connected to motor generator, check to be sure motor generator is running and producing power.
- If RV is connected to power supply by a land line, check to be sure line is sized properly to run air conditioner load and it is plugged into power supply.
- Check your 115 VAC fuse or circuit breaker to see if it is open.
- Check your 12 VDC Fuse or Circuit Breaker to see if it is open.

- After the above checks, call your local service center for further help. This unit must be serviced by qualified service personnel only.

When calling for service, always give the following:

- Air Conditioner Model Number and Serial Number found on Rating Plate located on Base Pan of Air Conditioner.
- Electronic Control Kit Part Number and Serial Number found on Rating Plate located on side of Kit.

RETURN AIR GRILLE MUST BE REMOVED FROM RETURN AIR COVER TO VIEW THESE RATING PLATES

INSTALLATION INSTRUCTIONS

1. PRECAUTIONS

WARNING

IMPROPER INSTALLATION MAY DAMAGE EQUIPMENT, COULD ENDANGER LIFE, CAUSE SERIOUS INJURY AND/OR PROPERTY DAMAGE.

- Read Installation and operating instructions carefully before attempting to start your air conditioner installation.
- The Dometic Corporation will not be liable for any damages or injury incurred due to failure in following these instructions.
- Installation must comply with the National Electrical Code and any State or Local Codes or regulations.
- DO NOT add any devices or accessories to this air conditioner except those specifically authorized by Dometic.
- This equipment must be serviced by qualified personnel and some states require these people to be licensed.

2. CHOOSING LOCATION FOR THE AIR CONDITIONER

This air conditioner is specifically designed for installation on the roof of a recreational vehicle (RV).

A. For One Unit Installation:

The air conditioner should be mounted slightly forward of center (front to back) and centered from side to side.

B. For Two Unit Installations:

Install one air conditioner 1/3 and one air conditioner 2/3's from front of RV and centered from side to side.

It is preferred that the air conditioner be installed in a relatively **flat and level** roof section measured with the RV parked on a level surface. **NOTE: UP TO AN 8° SLANT TO EITHER SIDE, OR FRONT TO BACK, IS ACCEPTABLE.**

C. AFTER LOCATION HAS BEEN SELECTED:

- Check for obstructions in the area where air conditioner will be installed.
- The roof must be designed to support 130 pounds when the RV is in motion. Normally 200 pound static load design will meet this requirement.

AIR CONDITION DIMENSIONS (On Top of Vehicle)

579, 590 & 595 SERIES

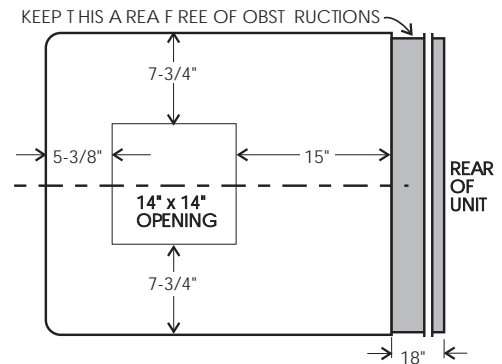

600 SERIES

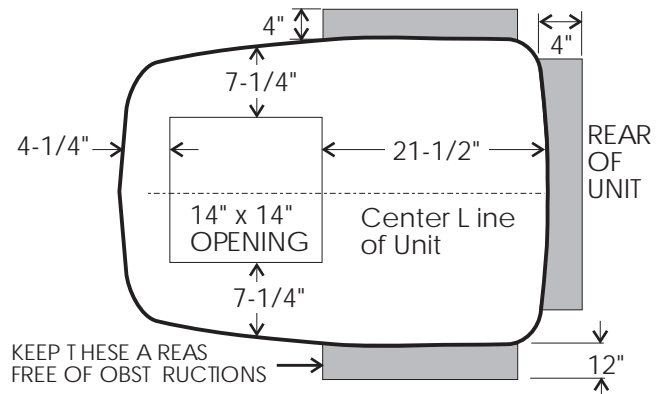

3. AIR DISTRIBUTION SYSTEM SIZING & DESIGN

The Installer of this Air Conditioner System must design the air distribution system for his particular application. Several requirements for this system **MUST** be met for the Air Conditioner to operate properly. These requirements are as follows:

- A. Roof cavity thickness must be between 2.00" to 5.50". This distance is measured between roof and ceiling surface.
- B. The total Cross-Sectional Discharge Area of outlet ducts from the Plenum Area under the Air Conditioner must be as follows:
 1. 579 & 600 Series; 17.5 sq. in.
 2. 590 & 595 Series; 21.0 sq. in.
- C. Duct Sizing Requirements as follows:

	Min.	Max.
1. Duct Depth (590 & 595 Series)	1-1/2"	2-1/4"
(579 & 600 Series)	1-1/4"	2-1/4"
2. Duct Width	7.00"	— — —
3. Total Duct Length	12 ft.	36 ft.
4. Duct Length (Short Run)	1/3 Total Length	

- D. Register Requirements as follows:

	Min.	Max.
1. Distance from Duct End	5"	8"
2. Distance from End of Elbow	15"	
3. Distance between Registers	24"	—
4. Total Number Required/AC	4	8
5. Number required per Run/AC	2	---
6. Free Area per Register	14 sq. in.	---

E. The Duct material must meet or exceed any agency or RVIA Standard that may be in existence at the time the RV is produced.

NOTE

IT IS THE RESPONSIBILITY OF THE INSTALLER OF THIS SYSTEM TO INSURE THE DUCT-WORK WILL NOT COLLAPSE OR BEND DURING OR AFTER THE INSTALLATION.

- F. All Discharge Air Ducts must be properly insulated to prevent condensation from forming on their surfaces or adjacent surfaces during operation of the Air Conditioner. This insulation must be R-7 minimum.
- G. Ducts and their joints must be sealed to prevent condensation from forming on adjacent surfaces during operation of the Air Conditioner.

NOTE

THE DOMETIC CORPORATION WILL NOT BE HELD LIABLE FOR ROOF STRUCTURAL OR CEILING DAMAGE DUE TO IMPROPERLY INSULATED OR SEALED DUCT-WORK.

- H. Return Air Opening must have 40 sq. in. minimum free area including the filter.
- I. Return Air to the Air Conditioner must be filtered to prevent dirt accumulation on Air Conditioner Cooling surface.
- J. Total System Pressure must be between the following:
 1. 0.55 to 0.90 in.W.C. for 579 Series
 2. 0.40 to 1.10 in.W.C. for 590 & 595 Series
 3. 0.12 to 0.65 in W.C. for 600 Series
 This is determined with the Air Conditioner Blower operation on High Speed and Return Air Filter and Grille in place.

NOTE

IT IS THE RESPONSIBILITY OF THE INSTALLER OF THIS AIR CONDITIONER SYSTEM TO INSURE THE STRUCTURAL INTEGRITY OF THE RV ROOF.

- K. The Thermostat must be located on an inside wall of the RV, 54" above the floor. The Thermostat must not be located near a heat source.

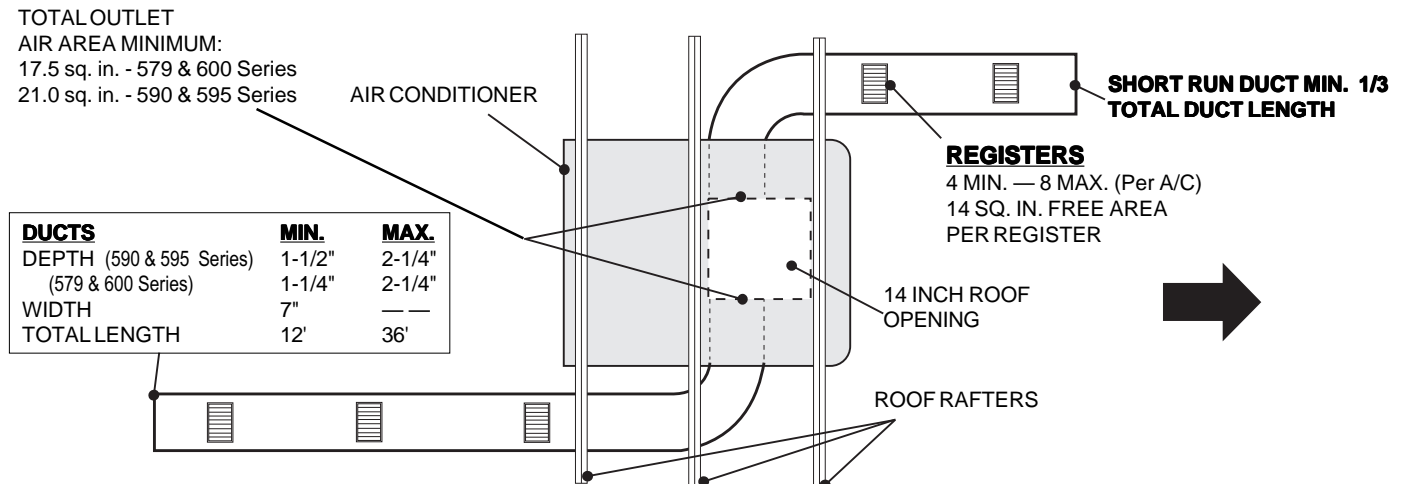

4. AIR DISTRIBUTION SYSTEM INSTALLATION

The Dometic Corporation recommends the basic configuration shown below for installing this Air Conditioner System. We have found by testing, that this configuration works best in most applications of this Air Conditioner System.

It is the responsibility of the Installer of this System to review each RV floor plan and determine the following:

- A. Duct size
- B. Duct layout
- C. Register size
- D. Register locations
- E. Thermostat location.

These items must be determined in conjunction with the Air Distribution System Sizing and Design Requirements listed in Section 3 of this manual.

ALTERNATE CONFIGURATIONS AND METHODS MAY BE USED WHICH STILL ALLOW THE AIR CONDITIONER TO OPERATE PROPERLY. HOWEVER, THESE ALTERNATE CONFIGURATIONS AND METHODS MUST BE APPROVED BY THE DOMETIC CORPORATION IN WRITING.

The following instructions are based upon the use of Dometic Return Air Kit No. 3105007 or 3105935. The electronic kit has mounting bolts supplied for use with this Kit.

A. Before preparing the ceiling opening, the type of system options must be decided upon. If a remote sensor is to be used, provision must be made for it. If the load shed option is to be used, wires must be run from the load shed control to the Dometic A/C. If a furnace is to be connected, wires must be run from the furnace to the Dometic A/C. **Read all of the following instructions before beginning the installation.**

B. ROOF AND CEILING OPENING PREPARATION

- 1) A 14" x 14" opening must be cut through the roof and ceiling of the RV. This opening must be located between the roof and reinforcing members.

! WARNING

THERE MAY BE ELECTRICAL WIRING BETWEEN THE ROOF AND THE CEILING. DISCONNECT ALL POWER SUPPLIES AND THE POSITIVE (+) TERMINAL FROM THE SUPPLY BATTERY. FAILURE TO FOLLOW THIS INSTRUCTION MAY CREATE A SHOCK HAZARD.

- 2) Mark a 14" x 14" square on the roof and carefully cut the opening.
- 3) Using the roof opening as a guide, cut the matching hole in the ceiling.

- 4) The opening created must be framed to provide adequate support and prevent air from being drawn from the roof cavity. Lumber 3/4" or more in thickness must be used. Remember to provide an entrance hole for power supplies, furnace wiring, 4-conductor telephone cable, remote sensing and load shed options as desired.
- 5) The 14" opening is part of the return air system of the Air Conditioner and must be finished in accordance with NFPA Standard 501C Section 2.7.
- 6) Route a copper 12 AWG, with ground, 115 VAC supply line from the fuse or circuit breaker box to the roof opening.
 - a. This supply line must be located in the front portion of the 14" opening.
 - b. The power supply **MUST** be on a separate 20 amp Time Delay Fuse or HACR Circuit Breaker.
 - c. Make sure at least 15" of supply wire extends into the roof opening. This ensures easy connection at the Junction Box.
 - d. Wiring must comply with all National, State and Local Wiring Codes.
 - e. Use a steel sleeve and a grommet or equivalent methods to protect the wire where it passes into the opening.
- 7) Route a dedicated 12 VDC supply line (18-22 AWG) from the RV's Converter or Battery to the roof opening.
 - a. This supply line must be located in the front portion of the 14" opening.
 - b. Make sure that at least 15" of supply wire extends into the roof opening.
 - c. **In a multiple zone installation, this wiring is required in only one of the 14" openings.**
- 8) If a Remote Temperature Sensor is to be used (Part No. 3106486.008), the connector end must be routed to the roof opening of the system which is till control. Make sure that at least 15" of the sensor cable extends into the roof opening. Mount the Remote Sensor in a location 54" above the floor and away from any heat source in the area that is to be controlled.
- 9) If a furnace is to be controlled by the system, the two furnace thermostat leads must be routed to the roof opening of the air conditioner that will control it. Make sure at least 15" of the furnace thermostat wires extend into the roof opening.
- 10) If an Energy Management System (EMS) is to be used with the control, two wires must be routed to the roof opening of the zone to be managed. The signal required for this function is a normally open relay contact. When the EMS calls for the compressor to shut off, the relay contacts should close. Make sure that at least 15" of the EMS wires extend into the roof opening.

- 11) Route a 4-conductor telephone cable (Part No. _____) from **Comfort Control Center** mounting position into the 14" roof opening. Make sure that at least 15" of the wire extends into the roof opening and 6" extend from the wall at the mounting position of the **Comfort Control Center**.
- 12) In the event that other A/C's are to be installed (additional zones) an additional 4-conductor telephone cable (Part No. _____) must be routed to the other A/C's. Make sure that at least 15" of the wire extends into the roof opening.

- c. **NEVER** expose it to direct heat from lamps, sun or other heat producing items.
- d. Avoid locations close to doors that lead outside, windows or adjoining outside walls.
- e. Avoid locations close to supply registers and the air from them.

- 2) If the system is to be used **WITH** a **Remote Temperature Sensor** in **ALL** zones, the comfort Control Center may be mounted anywhere that is convenient in the coach. Try to avoid hard to reach and hard to see areas.
 - a. Follow the same guidelines for mounting the Remote Sensor that would normally be followed in mounting the Comfort Control Center. (See previous paragraph).
- 3) A hole at least 1/2" diameter will be needed to route the cable through the wall.

C. AIR DISTRIBUTION DUCT INSTALLATION

Install the Air Distribution Ducts in the RV Roof Cavity. The Distribution System must meet:

1. RV's requirements
2. System requirements listed in Section 3 of this Manual.

Terminate the start of the Duct at the back edge of the 14" opening previously cut.

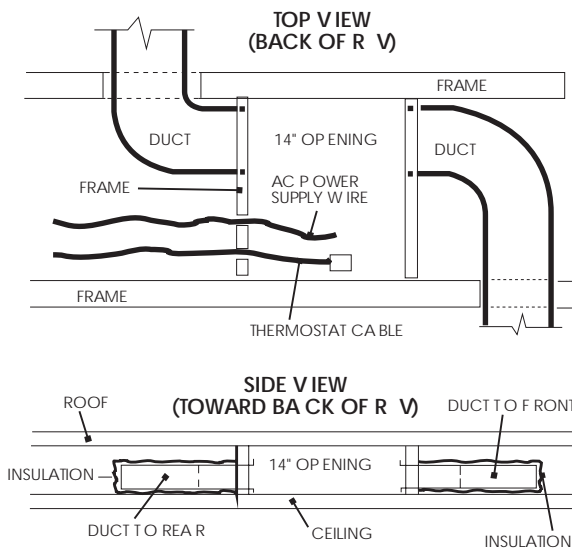

B. CONTROL CABLE INSTALLATION

A 4-conductor telephone cable must be routed from the roof opening to the **Comfort Control Center**.

- 1) Choose the shortest, most direct route from the 14" opening to the Comfort Control Center location selected. Leave 6" of cable extending through the wall.
- 2) The cable that should be used is a flat, 4-conductor telephone cable. (Part No. _____)
- 3) The cable must be terminated with a telephone RJ-11 connector (Part No. _____). Refer to the crimp tool manufacturer for crimping instructions. Ensure that the cable is installed into the connector correctly before crimping. (See figure below).

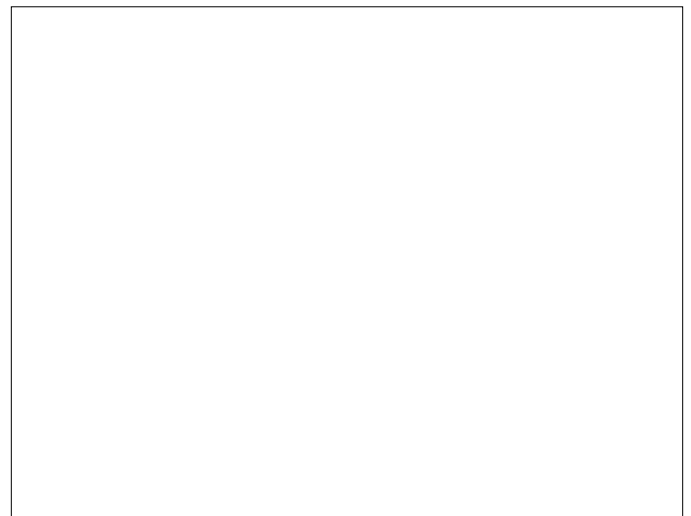

5. DOMETIC COMFORT CONTROL CENTER & CABLE INSTALLATION

A. LOCATION

- 1) If the system is to be used without a Remote Temperature Sensor, the proper location of the Comfort Control Center is very important to ensure that it will provide a comfortable RV temperature. Observe the following rules when selecting a location.
 - a. Locate the Comfort Control Center 54" above the floor.
 - b. Install the Comfort Control Center on a partition, not on an outside wall.

C. COMFORT CONTROL CENTER INSTALLATION

- 1) Carefully remove the base plate from the Comfort Control Center. This may be accomplished by inserting a screwdriver under the tab on the bottom edge of the front cover and gently prying. (See Figure below).

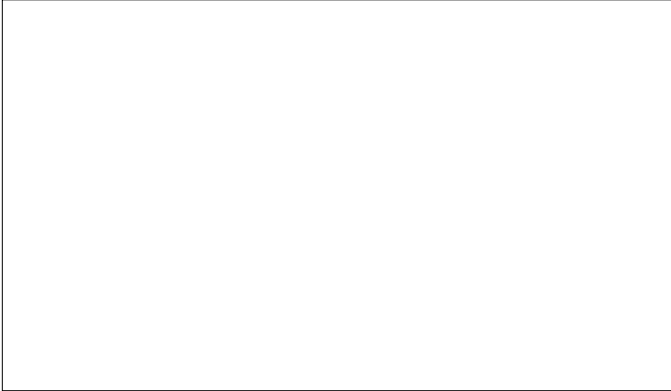

- 2) Insert the telephone cable through the hole in the base plate and mount the plate to the wall with the two screws provided. Check the alignment to ensure level installation.
- 3) Install the control cable RJ-11 connector into the back of the Comfort Control Center and gently press the _____ onto the base plate.

6. PLACING THE AIR CONDITIONER ON THE ROOF

- A. Remove the Air Conditioner from the carton and discard.

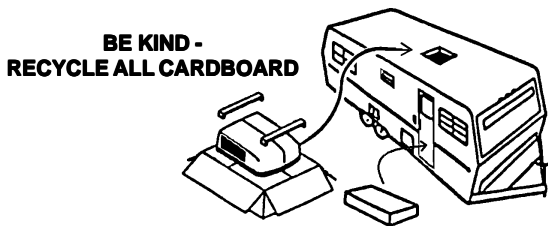

- B. Place the Air Conditioner on the roof.

! CAUTION

USE CARE IN LIFTING. THIS UNIT WEIGHS APPROXIMATELY ONE HUNDRED (100) POUNDS.

- C. Lift and place the unit over the prepared opening using the gasket on unit as a guide. The blunt end goes toward the rear of the RV.

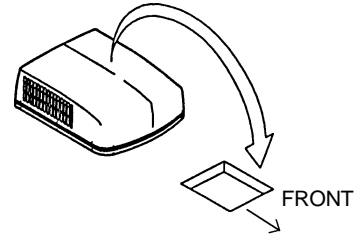

! CAUTION

DO NOT SLIDE THE UNIT. THIS MAY DAMAGE THE NEOPRENE GASKET ATTACHED TO THE BOTTOM AND CREATE A LEAKY INSTALLATION.

- D. Place 3106475.001, Electronic Kit and _____, Return Air Cover Kit, inside the RV. These cartons contain mounting hardware for the air conditioner and will be used inside the RV.

This completes the outside work. Minor adjustments can be done from the inside of the RV if required.

7. INSTALLATION OF AIR CONDITIONER

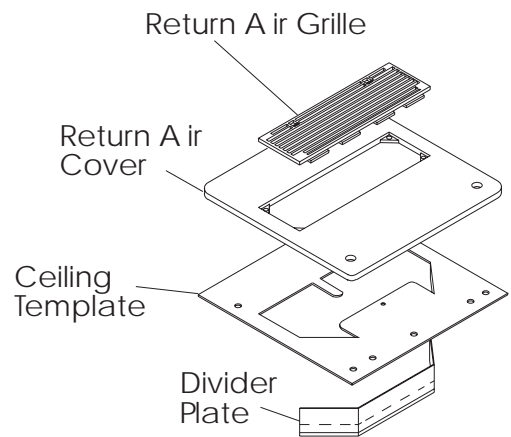

A. INSTALLATION OF CEILING TEMPLATE

- 1) Check gasket alignment of the Air Conditioner over roof opening and adjust if necessary. Unit may be moved from below by slightly lifting and sliding.
- 2) Reach up into the return air opening of the Air Conditioner and pull the unit electrical cord down for later connection.

- 3) Remove Return Air Cover and Ceiling Template from the 3105007 or 3105935, return air cover kit carton.

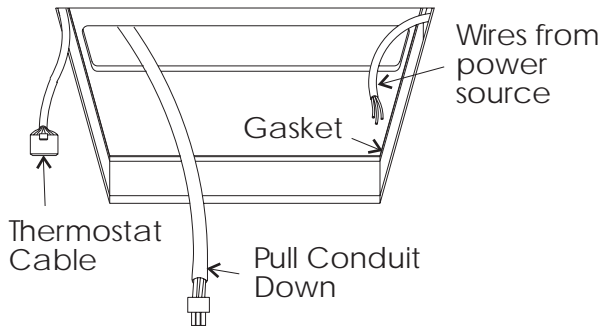

- 4) Remove Parts Package, Electronic Box and Thermostat from Electronic Kit, Carton No. _____.
- 5) Locate 1/4" unit mounting bolts in the parts package.
- 6) Take the ceiling template and hold up to the 14" opening. Be sure the solid end faces the rear of the RV.
- 7) Start each mounting bolt through the ceiling template and up into the unit base pan by hand.

EVENLY TIGHTEN MOUNTING BOLTS TO A TORQUE OF 40 TO 50 INCH POUNDS

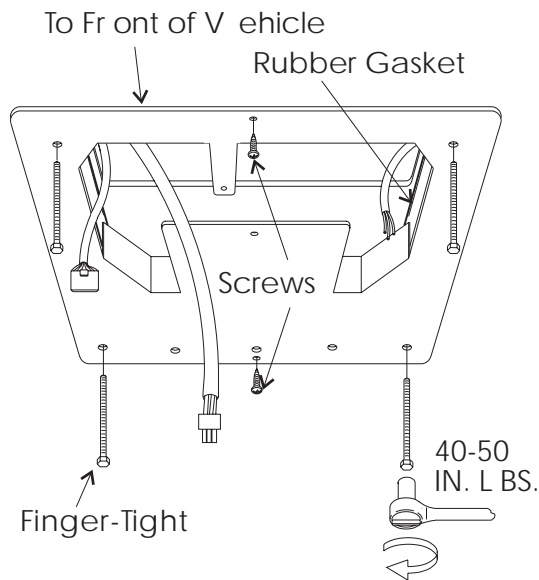

This will compress the roof gasket to approximately 1/2". The bolts are self locking so over tightening is not necessary.

- 8) Install wood screw in each end of ceiling template. This insures a tight fit of return air cover to ceiling.

B. INSTALLATION OF DIVIDER PLATE

- 1) Measure the ceiling to roof thickness:
 - a. If distance is 2.00" - 3.75", remove perforated tab from Divider Plate.
 - b. If distance is 3.75" - 5.50", remove no tabs.
- 2) Remove the backing paper from double sided tape located on Ceiling Template.

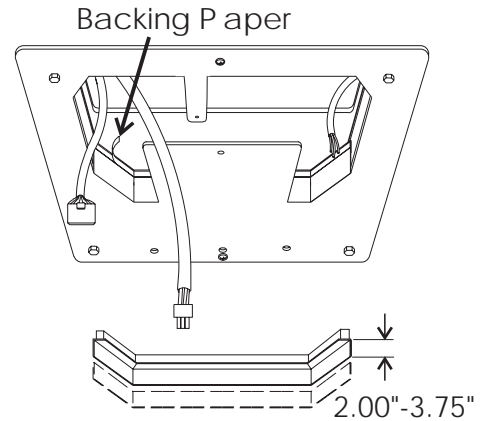

- 3) Place Divider Plate up to bottom of Air Conditioner base pan firmly. The foam tape on the divider plate must seal to bottom of base pan.

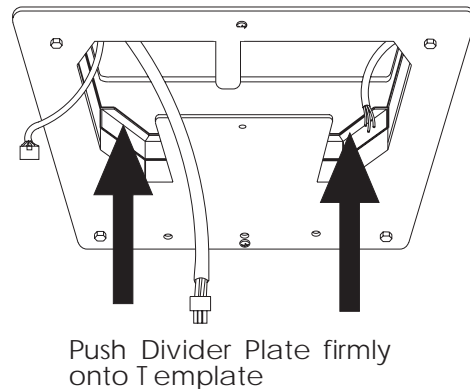

Note: The adhesive on double sided tape is extremely sticky. Divider Plate must be properly positioned before pressing in place.

4. With slight pressure then push divider plate against exposed double sided tape on ceiling template.
5. Locate 1/8" x 7" x 18" self-adhesive insulation supplied with the Return Air Kit.
6. Remove the backing paper from the insulation and carefully stick onto the ceiling template divider panel.

Note: The adhesive on insulation is extremely sticky. Be sure part is located where desired before pressing into place. We recommend pulling off part of backing paper, locating part and then remove backing paper as insulation is pressed into place.

- a. Excess width is intended to seal the divider plate to the sides of the 14" opening, This is to prevent cold discharge air from circulating into the Air Conditioner return air opening.
- b. If the insulation is too high, stick the excess height of insulation to the Air Conditioner base pan. Note: Do not cover up unit rating plate.

Place insulation in position
(Do not Cover unit rating plate)

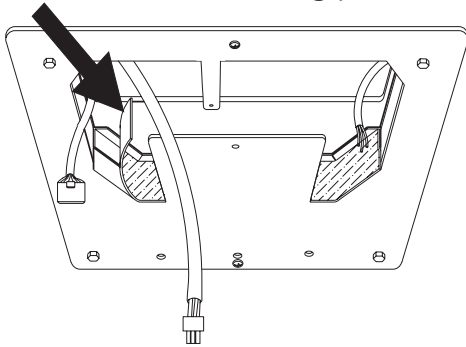

C. INSTALLATION OF ELECTRONIC CONTROL BOX

NOTE: If your installation includes the optional Electric Heat Kit, install it at this time. This optional Heat Kit is approved for use on 590 Series Air Conditioners only. Follow the instructions with the heat package for its installation procedure.

- 1) Terminate the 4-conductor telephone cable(s) protruding into the 14" roof opening. The cable(s) must be terminated with a telephone RJ-11 connector (Part No. _____). Refer to the crimp tool manufacturer for crimping instructions. Ensure that the cable is installed into the connector correctly before crimping. (See figure below).
- 2) Remove the screw holding the junction box cover to the **A/C Control Box**. Remove the cover.

579 AND 590 SERIES

- 1) Snap the **Freeze Control Sensor** (Part No. 3106480.001) onto the return bend of the evaporator coil. (See figure below).
 - a. Locate "D" shaped notch in the flange of the evaporator coil.
 - b. Place the horseshoe end of the **Freeze Control Sensor** through this notch and snap it onto the return bend. When positioned correctly, the control wires will be 90 degrees to the direction of the coil fin surface.
- 2) Plug the unit electrical cord into the mating connector on the **Electronic Control Box**. These connectors are polarized and will easily snap together. **DO NOT FORCE**.
- 3) Plug the telephone cable(s) into the telephone jack(s) visible on the side of the **Electronic Control Box**. (It does not matter which one.)
- 4) Locate the **Electronic Control Box** on the ceiling template.
- 5) Drive two #10 x 3/8 blunt point phillips head screws (provided in the parts package) through the ceiling template into the holes in the **Electronic Control Box** to hold it in place.

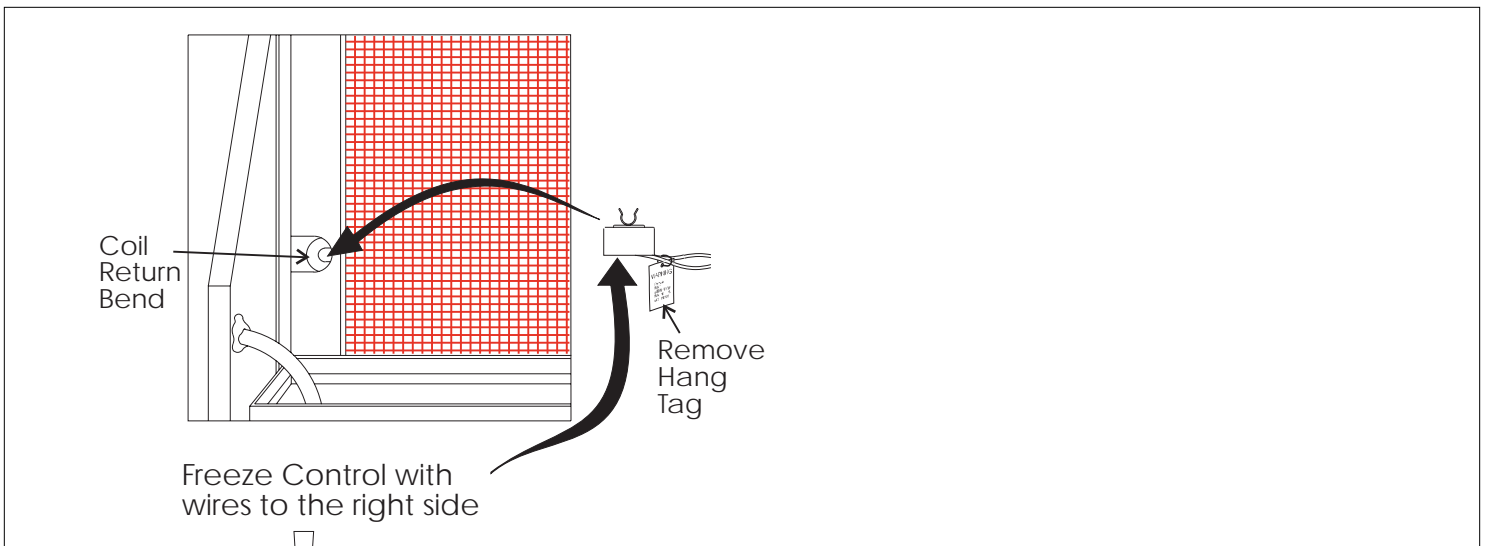

600 SERIES

- 1) Snap the Freeze Control Sensor (Part No. 3106480.001) onto the return bend of the evaporator coil. Located at right side of evaporator. (See figure below).

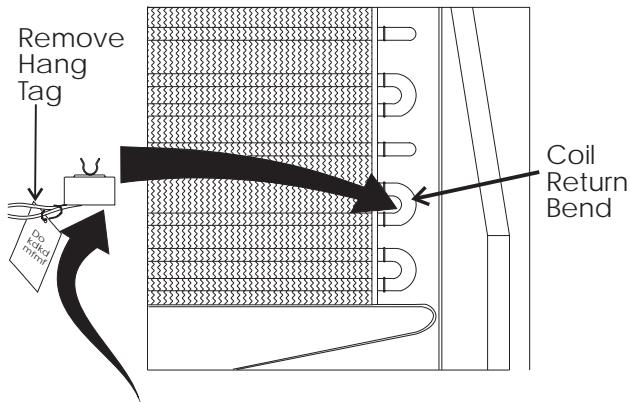

Freeze Control with wires.

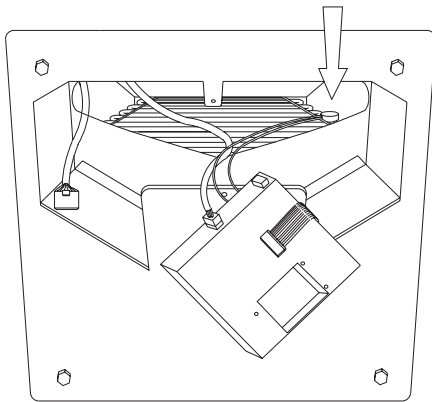

- a. Locate vertical return bend at lower right of evaporator coil.
- b. Place the horseshoe end of the Freeze Control onto this coil return bend and snap into place. When positioned correctly, control wires will be 90 degrees to the direction of the coil fin surface.

D. CONNECTION OF LOW VOLTAGE WIRES

! WARNING

Ensure that the 12 VDC power is shut off.

- 1) Route the **Remote Temperature Sensor** cable, if applicable, through the grommet in the **Electronic Control Box** and attach it to the connector that matches its color.
- 2) Connect the previously run 12 VDC to the red and black wires protruding from the **Electronic Control Box**. (In multiple zone installations, this needs to be done at only one zone.) Connect +12 VDC to the red wire; -12 VDC to the black wire.

- 3) Connect the previously run furnace thermostat wires (if applicable) to the blue wires protruding from the **Electronic Control Box**. The polarity of these connections does not matter.
- 4) Connect the previously run Energy Management System wires (if applicable) to the yellow wires protruding from the **Electronic Control Box**. The polarity of these connections does not matter.

E. ELECTRONIC CONTROL BOX CONFIGURATION

- 1) Adjust the dip switches visible in the Electronic Control Box according to the options that are installed. (See figure below).

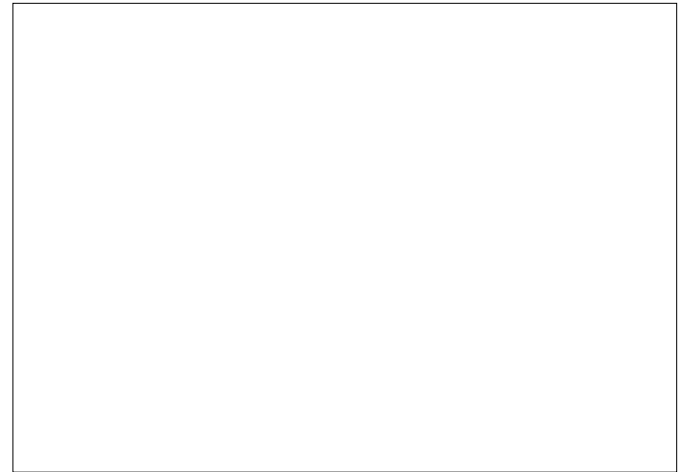

F. CONNECTION OF 115 VOLT POWER SUPPLY

- 1) Route the previously run power supply line through the Romex Connector and into the **Electronic Control Box** Junction Box.
- 2) Connect the white to white; black to black; and green to green or bare copper wire using appropriate sized twist wire connectors. **Tape** the twist wire connectors to the supply wiring to assure they do not vibrate off.
- 3) Tighten screws on strain relief connector being careful not to pinch and cut into the insulation on power supply leads.
- 4) Push excess wires into junction box. Replace the junction box cover onto the **Electronic Control Box**.

G. SYSTEM CHECKOUT & CONFIGURATION

Now that the system is installed, it is necessary to check all operations and then configure the electronics.

Refer to the Owner's portion of this manual for a description of the air conditioner operation.

- 1) **SYSTEM CHECKOUT:** Verify that all features of the installed system work. Check fan speeds, cooling mode, furnace (if connected) and heat strip. If the features do not work, check all wiring and confirm that the correct options have been selected on the Electronic Control Box. (See paragraph 7.E)
- 2) **SYSTEM CONFIGURATION:** If all features are functioning, perform the following configuration procedure:
 - a. Simultaneously depress the **UP** and **DOWN** pushbuttons on the **Comfort Control Center** for at least one second. This completes the system configuration.

H. COMPLETE UNIT WIRE CONNECTIONS

1. Connect the air conditioner ribbon cable connector to the thermostat cable end connector. The connectors are polarized and will easily snap together. **DO NOT FORCE.**

I. INSTALLATION OF RETURN AIR COVER

1. Remove Return Air Grille from the Return Air Cover.
2. Place the Return Air Cover up to Ceiling Template.
3. Install Cover to Template with #8 x 3/8" blunt point phillips head screws provided (6 required).
4. Reinstall Return Air Grille into Return Air Cover.
5. Install two (2) hole plugs into screw holes in back of return air grille. Align tabs with mating notches and snap into place.

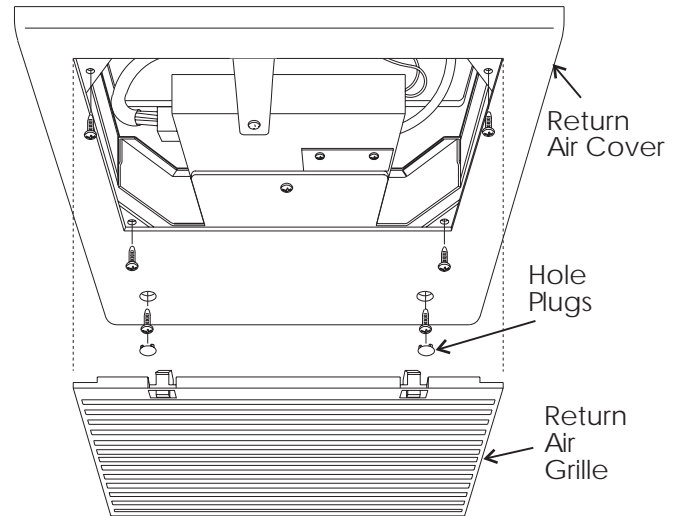

ELECTRONIC FIELD WIRING DIAGRAM

UNIT FIELD WIRING DIAGRAM

